

5

Building Blocks 2: Amplifiers, Mixers etc

Peter Goodson, G4PCF

For an amateur designing a complex circuit, it is normally a good idea first to draw the proposed circuit in block diagram form. For example, Fig 5.1 shows the block diagram of a proposed 80m SSB receiver.

- The block diagram shows the intended signal flow. Normally, inputs are shown on the left of the block diagram and outputs are on the right. Therefore, the signal flows from left to right.
- The block diagram does not show the 0V (ground) connections between the stages. It is assumed that all stages have a common 0V connection.
- Each block in the diagram has an intended function, eg mixer, amplifier, oscillator.
- At the block diagram stage of designing, the designer may have no idea about what circuits will be used to 'fill' the blocks.
- The block diagram can be used to set the gain distribution.
- For complex circuits, the block diagram is easier to understand than the complete circuit diagram.
- The block diagram can be used to check for potential spurious responses.
- The block diagram can be used to set the noise figure / gain requirements of the front-end.

See other chapters in this handbook for many examples of block diagrams. Once the designer is happy that the diagram represents a viable design, each of the blocks can be 'filled in'. The purpose of these Building Blocks chapters is to present examples of circuits which can be used to fill the blocks.

Some building blocks are standard circuits using discrete semiconductors, and some are made up from application-specific integrated circuits. The performance of building blocks can be described by the following parameters.

- **Gain** describes the available AC power gain of the circuit from input to output. The source and load impedance may also need to be specified for the gain specification to be useful. Gain is normally expressed in dB.

- **Isolation** (normally between the ports of a mixer) refers to the input applied to one port affecting whatever is connected to another port. In the simplest of receivers that uses a mixer without much isolation, peaking the antenna tuning circuit connected to the signal input may 'pull' the frequency of an unbuffered free-running oscillator connected to the local oscillator (LO) port. Conversely, the LO signal may unintentionally be transmitted from the antenna. Isolation is normally expressed in dB.
- **Noise** is generated in all circuits. It is quantified as a 'noise figure', expressed in decibels over the noise power generated by a resistor at the prevailing temperature, eg 50Ω at 27 °C. For example, if front-end mixer noise is significant as compared to the smallest signal to be processed, the signal-to-noise ratio will suffer. The same noise level or 'noise floor', in terms of dBm, is shown in Fig 5.2. Below 10MHz, however, atmospheric noise will override receiver noise and most mixers will be adequate in this respect.
- **Overload** occurs if an input signal exceeds the level at which the output is proportional to it. The overloading input may be at a frequency other than the desired one. Overload is normally expressed in dBm.
- **Compression** is the gain reduction which occurs when the signal input magnitude exceeds the maximum the circuit can handle in a linear manner. The input level for 1dB of gain reduction is often specified. Note the bending of the 'fundamental component' line in Fig 5.2. The signal input level should be kept below the one causing this bending.
- **Intermodulation** products are the result of non-linearity in the circuit, and are generated when the input contains two or more signals. Intermodulation performance is often specified as the power level in dBm of the 'third-order intercept point'. This is the fictitious intersection on a signal input power versus output power plot, Fig 5.2, of the extended (dashed) fundamental (wanted) line and the third-order intermodulation line. Note that the third-order line rises three times steeper than the fundamental line.

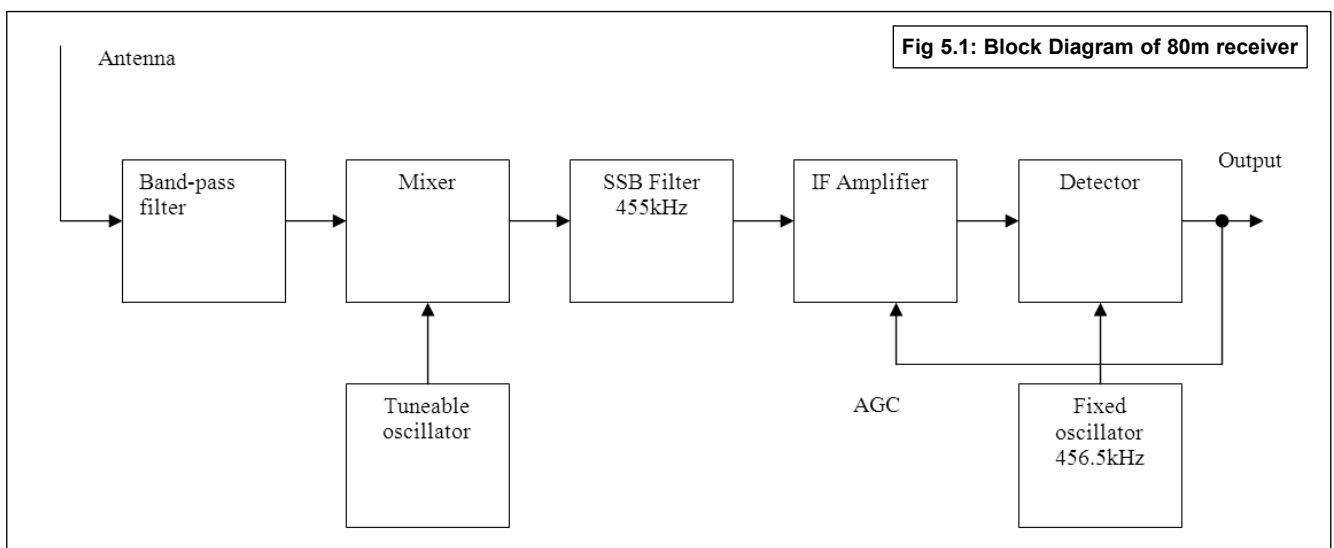

Fig 5.1: Block Diagram of 80m receiver

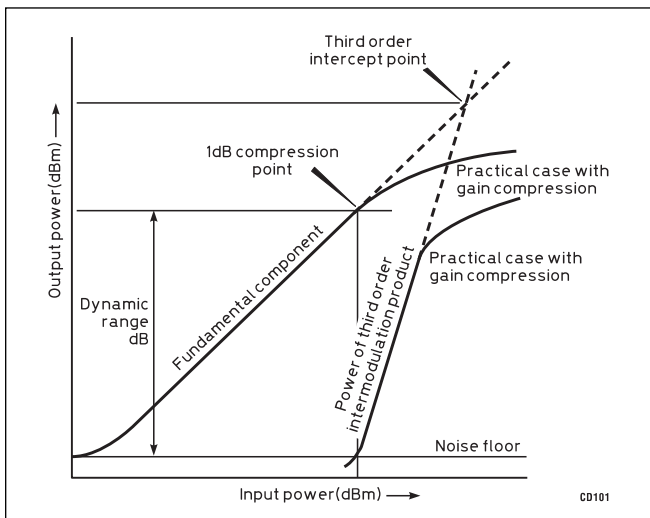

Fig 5.2: Noise floor, 1dB compression point, dynamic range and 3rd-order intercept indicated on a mixer output vs input plot (GEC-Plessey Professional Products IC Handbook)

- **Harmonic distortion** is a result of non-linearity in the circuit. The result of harmonic distortion is to produce, at the output, harmonics of the input fundamental frequency. Even-order harmonics (ie 2nd, 4th, 6th etc) can be virtually eliminated by the use of push-pull circuits.
- **Operating impedance.** This defines the input and output impedances of the circuit, or the source and load impedances for which the circuit is designed. Circuits which operate at low impedance (typically 50 ohms) can be designed to have wide bandwidth. They normally operate at low voltage, high current. Circuits which operate at high impedance (typically 1000 ohms) tend to have reduced bandwidth. They tend to operate at a higher voltage, but with lower current consumption than low-impedance circuits.
- **Bandwidth** defines the range of frequencies over which the circuit is designed to function. A wideband circuit design is one which typically covers several octaves and would be used, for example, for a circuit required to operate over 1.8 to 52MHz. Wideband design is not always necessary for amateur use, and is of no value for those who only operate on one amateur band.
- **Power consumption** is the power which the circuit draws from the DC power supply. The power drawn is given by the product of the DC supply voltage multiplied by the operating current. Power consumption is most significant when the equipment is operated from batteries, because high power consumption will reduce battery life.

Building blocks may be classed as passive or active. Passive circuits require no power supply and therefore provide no gain. In fact they may have a significant insertion loss. Examples of passive circuits are diode mixers, diode detectors, LC (inductor + capacitor) filters, quartz filters and attenuators. Examples of active circuits are amplifiers, active mixers, oscillators and active filters.

MIXERS

Terms and Specifications

A mixer is a three-port device, of which two are inputs and the third is the output. The output voltage is the mathematical product of the two input voltages. In the frequency domain, this can

be shown to generate the sum and difference of the frequencies on the two input ports. The following circuits are better known by the specific function that they perform, but they are all examples of circuits which operate as a mixer, or multiplier.

- Front-end mixer
- Detector
- Product detector
- Synchronous detector
- Demodulator
- Modulator
- Phase detector
- Quadrature FM detector
- FM Stereo decoder
- TV Colour demodulator
- Analogue multipliers
- Multiplexer
- Sampling gate

These all use the principle of multiplying the two input signals. However, there are differences in the performance of the circuits. For example, a mixer required to operate as the front-end mixer in a high-performance receiver would be designed for high dynamic range, whereas a mixer operating as a detector in the back-end of a receiver only needs very limited dynamic range. This is because the level of signal into the demodulator is constant (due to the receiver AGC system).

It should be noted that there is a distinction between mixers (or multipliers) in this context and mixers which are used in audio systems. The mixers used in audio systems operate by adding the input voltages, and the function is therefore mathematically different.

Of the two inputs to a mixer, one, f_s , contains the intelligence, the second, f_o , is specially generated to shift that intelligence to (any positive value of) $\pm f_s \pm f_o$, of which only one is the desired output. In addition, the mixer output also contains both input frequencies, their harmonics, and the sum and difference

Unbalanced mixer					
	f_o	$2f_o$	$3f_o$	$4f_o$	$5f_o$
fs	$f_o \pm f_s$	$2f_o \pm f_s$	$3f_o \pm f_s$	$4f_o \pm f_s$	$5f_o \pm f_s$
2fs	$2f_s \pm f_o$	$2f_o \pm 2f_s$	$3f_o \pm 2f_s$	$4f_o \pm 2f_s$	$5f_o \pm 2f_s$
3fs	$3f_s \pm f_o$	$3f_s \pm 2f_o$	$3f_o \pm 3f_s$	$4f_o \pm 3f_s$	$5f_o \pm 3f_s$
4fs	$4f_s \pm f_o$	$4f_s \pm 2f_o$	$4f_s \pm 3f_o$	$4f_o \pm 4f_s$	$5f_o \pm 4f_s$
5fs	$5f_s \pm f_o$	$5f_s \pm 2f_o$	$5f_s \pm 3f_o$	$5f_s \pm 4f_o$	$5f_o \pm 5f_s$
Balanced mixer - half the number of mixer products					
	f_o	$2f_o$	$3f_o$	$4f_o$	$5f_o$
fs	$f_o \pm f_s$	$2f_o \pm f_s$	$3f_o \pm f_s$	$4f_o \pm f_s$	$5f_o \pm f_s$
3fs	$3f_s \pm f_o$	$3f_s \pm 2f_o$	$3f_o \pm 3f_s$	$4f_o \pm 3f_s$	$5f_o \pm 3f_s$
5fs	$5f_s \pm f_o$	$5f_s \pm 2f_o$	$5f_s \pm 3f_o$	$5f_s \pm 4f_o$	$5f_o \pm 5f_s$
Double-balanced mixer - one quarter the number of mixer products					
	f_o	$2f_o$	$3f_o$	$4f_o$	$5f_o$
fs	$f_o \pm f_s$	-	$3f_o \pm f_s$	-	$5f_o \pm f_s$
3fs	$3f_s \pm f_o$	-	$3f_o \pm 3f_s$	-	$5f_o \pm 3f_s$
5fs	$5f_s \pm f_o$	-	$5f_s \pm 3f_o$	-	$5f_o \pm 5f_s$

f_o is the local oscillator. Note that a product such as $2f_o + f_s$ is known as a third-order product, $3f_s + 3f_o$ as a sixth-order product and so on

Table 5.1: Mixing products in single, balanced and double-balanced mixers

frequencies of any two of all those. If any one of these many unwanted mixer products almost coincides with the wanted signal at some spot on a receiver dial, there will be an audible beat note or birdie at that frequency. Similarly, in a transmitter, a spurious output may result.

In a general-coverage receiver and multi-band transmitter design, the likelihood of spurious responses occurring somewhere in the tuning range is very high, but this problem can be reduced by the use of balanced mixers. When a signal is applied to a balanced input port of a mixer, the signal, its even harmonics and their mixing products will not appear at the output. If both input ports are balanced, this applies to both f_o and f_s , and the device is called a double-balanced mixer. **Table 5.1** shows how balancing reduces the number of mixing products. Note that products such as $2f_o \pm f_s$ are known as third-order products, $3f_o \pm 3f_s$ as sixth-order and so on. Lower-order products are generally stronger and therefore more bothersome than higher-order products. It should be noted that the term 'balanced' (and 'double balanced') in this context does not necessarily mean that the inputs are in a balanced form (ie with differential inputs) but rather refers to the internal configuration of the mixer circuit.

Practical Mixer Circuits

Virtually any device which has a non-linear characteristic can be used as a mixer, which probably explains why so many different mixer circuits and configurations have been published. However, this chapter concentrates on using common semiconductor devices like diodes, transistors and FETs. Even with a limited range of devices, there is still a wide range of circuit configurations which can be built. None of them is expensive to build, which enables the amateur to experiment with circuit configurations.

Passive mixers

Passive mixers are usually built using diodes as the non-linear component. A single-diode mixer is frequently used in microwave equipment. As a diode has no separate input ports, it provides no isolation between inputs. The mixer diode D1 in **Fig 5.3**, however, is used in an interdigital filter [1]. Each input frequency readily passes by its high-Q 'finger' to the lower-Q (diode-loaded) finger to which D1 is connected but cannot get beyond the other high-Q finger which is tuned to the other input frequency. In this design $f_s = 1296\text{MHz}$ and $f_o = 1268\text{MHz}$. The 30pF feedthrough capacitor at the mixer output terminal acts as a short to earth for both input frequencies, but is part of a tuned circuit (not shown) at the output frequency of $1296 - 1268 = 28\text{MHz}$. Diode D2 is not part of the mixer, but is the last link in a local oscillator chain. D2 operates as a quadrupler from 317 to 1268MHz. To get a good noise figure, the mixer D1 is a relatively expensive microwave diode. In the multiplier spot, a cheaper diode suffices.

Fig 5.4 is a single-balanced version of the diode mixer. It is popular for direct-conversion receivers where the balance reduces the amount of local oscillator radiation from the receiving antenna. The RC output filter reduces local oscillator RF reaching the following AF amplifier.

Fig 5.5 shows a diode ring double-balanced mixer. This design has been used for many decades and its performance can be second to none. Diode mixers are low-impedance devices, typically 50 ohms. This means that the local oscillator must deliver power, and typically 5mW (+7dBm) is required for best dynamic range. The low impedances mean that the circuit is essentially a wideband design. The balance of this mixer may be further improved by adding external transformers as shown in the chapter on HF receivers.

Diode mixers can be built by the amateur, and for very little cost. The four diodes should be matched for both forward and

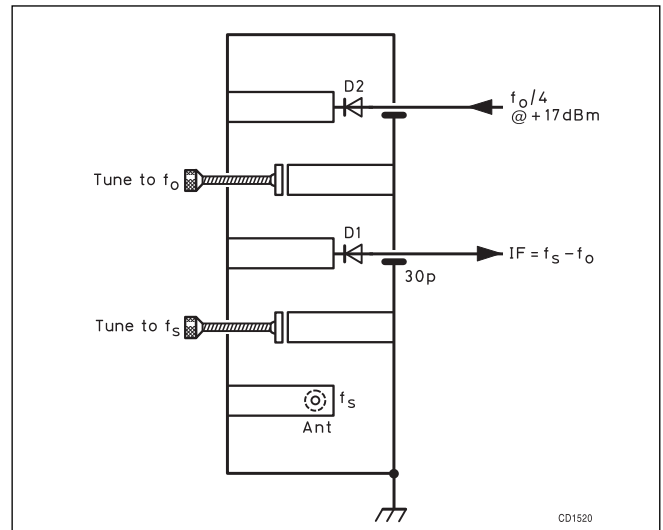

Fig 5.3: Single-diode mixer for 1296MHz. An interdigital filter provides isolation between ports. D1 is the mixer and D2 is the last multiplier in the local oscillator chain

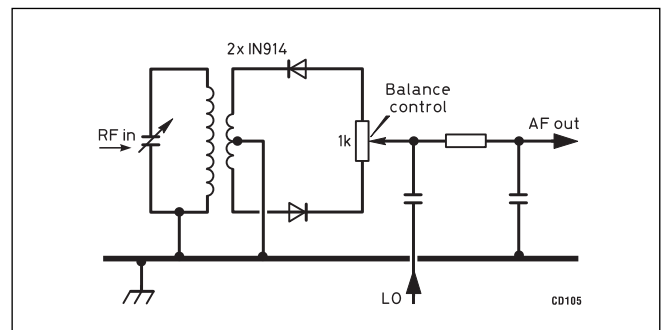

Fig 5.4: In this two-diode balanced mixer for direct conversion receivers, balancing helps to keep LO drive from reaching the antenna

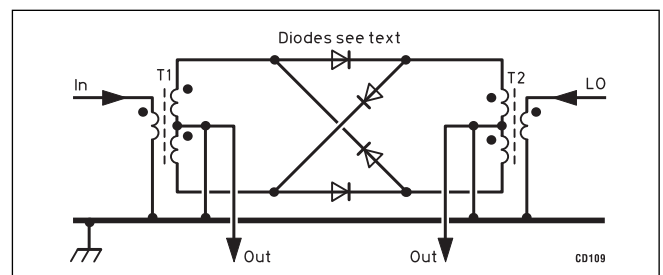

Fig 5.5: Diode ring mixers are capable of very high performance at all the usual signal levels but several sometimes costly precautions have to be taken to realise that potential; see text. Further improvement of the balance can be obtained by the use of push-pull feed to the primaries of T1 and T2 and feeding the output from between the T1 and T2 centre-taps into a balanced load

reverse resistance. Inexpensive silicon diodes like the 1N914 can be used, but Schottky barrier types such as the BA481 (for UHF) and BAT85 (for lower frequencies and large-signal applications) are capable of higher performance. The bandwidth of the mixer is determined largely by the bandwidth of the transformers. For wide-band operation, these are normally wound on small ferrite toroids. For HF and below, the Amidon FT50-43 is suitable, and 15 trifilar turns of 0.2mm diameter enamelled copper wire are typical. The dots indicate the same end of each wire.

Complete diode mixers can be bought ready-made and are now available quite cheaply. These are usually manufactured as double-balanced mixers and one of the cheapest is the Mini-Circuits SBL-1. They contain four matched diodes and two transformers and are available in a sealed metal package. The advantage of these is that their mixing performance is specified by the manufacturer. When studying mixer data sheets, it can be seen that the main difference between mixer models is the intermodulation performance. The models which have the best intermodulation performance also require much greater local oscillator input power. Mixers can be purchased which have local oscillator requirements from about 0dBm up to about +27dBm. Commercial diodes mixers are typically specified to operate over 5 - 500MHz, but should still offer reasonable performance beyond these frequencies.

Passive mixers have a conversion loss of about 7dB. If such a mixer is used as a receiver front-end mixer, this loss will contribute significantly to the noise figure of the receiver. It is recommended that the mixer is followed immediately by an IF amplifier. If the receiver is being used above about 25MHz, a low noise-figure receiver is important, and this IF amplifier must, therefore, be a low-noise type.

The performance of passive diode mixers is normally specified with the three ports all terminated with 50 ohms. Failure to do this on any port may increase third-order intermodulation products. On the LO port, as it is difficult to predict the output impedance of an oscillator circuit over a wide frequency range, it is best to generate more LO power than that required by the mixer and insert a resistive attenuator, 3-6dB being common. Using this method tends to force the other two ports to more closely adopt an impedance of 50Ω.

Reactive termination of the output port can increase conversion loss, spurious responses and third-order IMD. Most mixers work into a filter to select the desired frequency. At that frequency, the filter may have a purely resistive impedance of the proper value but at the frequencies it is designed to reject it certainly does not. If there is more desired output than necessary, an attenuator is indicated; if not, the filtering may have to be done after the following amplifier, which may be the one making up for the conversion loss. This problem can be overcome by use of the 'constant-R' matching network [2].

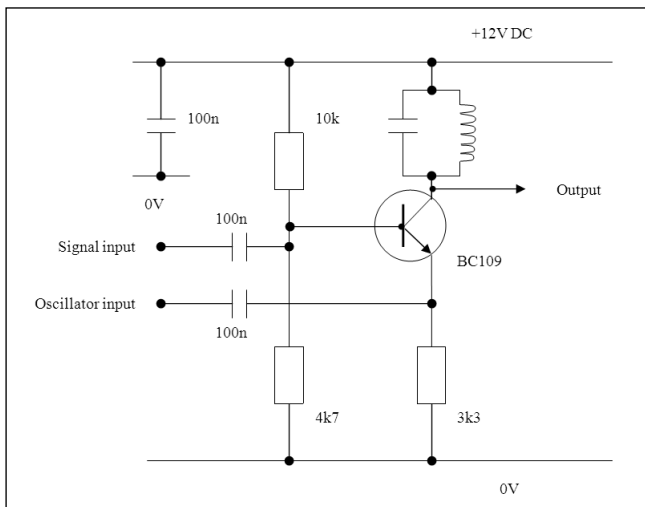

Fig 5.6: A transistor mixer

Active mixers

An active mixer is able to provide gain at the same time as providing the mixing action. It is normal to use active devices like bipolar transistors, junction FETs, single and dual-gate MOSFETs, or valves. FETs are particularly good as mixers because they have a strong second-order response in their characteristic curve, and it is the second-order response which gives the mixing action in active mixers.(see Table 5.2). Active devices like transistors have the advantage that they have three terminals (E-B-C) so they are very easy to connect up as a three-port circuit. Some devices, for example the dual-gate MOSFET, are often shown in their data sheet being operated as a mixer. However, for many devices the data sheet doesn't describe their use as a mixer, but this does not necessarily preclude them from being used.

Fig 5.6 shows what is probably the simplest active mixer. This employs a single transistor, and is a non-balanced mixer, but is able to provide significant gain.

Fig 5.7 shows what is probably the simplest FET mixer circuit. It is a non-balanced mixer but does provide some isolation between ports. It also provides low noise, high conversion gain and a reasonable dynamic range. The latter can be improved by the use of an FET, such as the J310, biased for high source current, say 20mA, depending on the device. JFETs require careful

Device	Advantages	Disadvantages
Bipolar transistor	Low noise figure High gain Low DC power	High intermodulation Easy overload Subject to burn-out
Diode	Low noise figure High power handling High burn-out level	High LO drive Interface to IF Conversion loss
JFET	Low noise figure Conversion gain Excellent square-law characteristic Excellent overload High burn-out level	Optimum conversion gain not at optimum square-law response level High LO power
Dual-gate MOSFET	Low IM distortion AGC Square-law characteristic	High noise figure Poor burn-out level Unstable

Table 5.2: Comparison of semiconductor performance in mixers

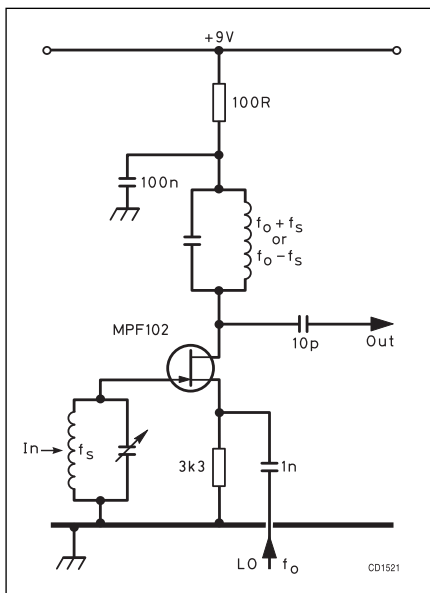

Fig 5.7: A single JFET makes a simple inexpensive mixer. The LO drives a low-impedance port, requiring it to supply some power

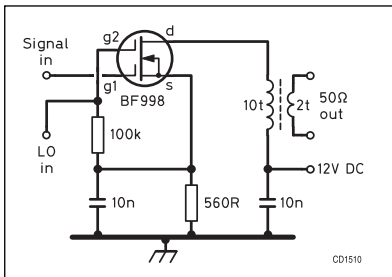

Fig 5.8: The two gates of a dual-gate MOSFET present high impedance to both the signal input and the local oscillator. A self-biasing configuration is shown here

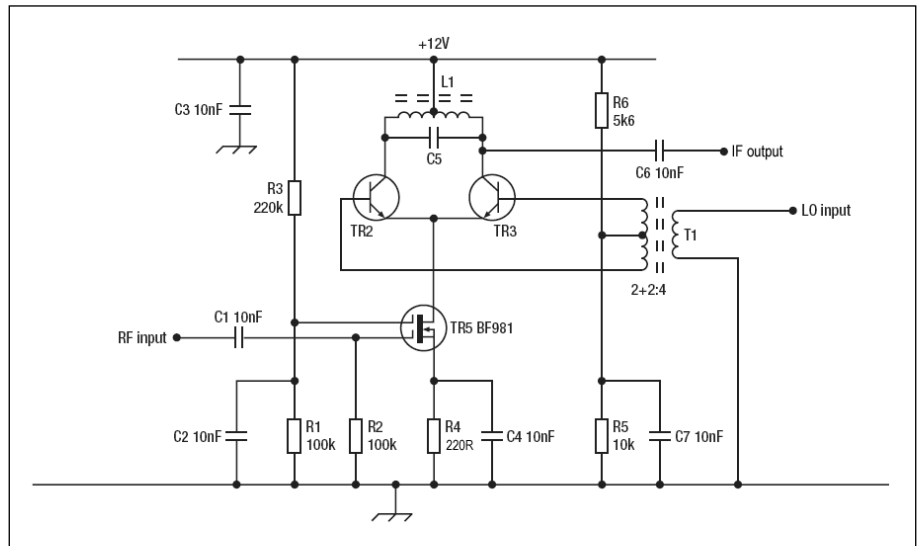

Fig 5.9: A single-balanced mixer. This circuit has been used successfully

adjustment of bias (source resistor) and local oscillator input level for best performance.

The signal is applied to the high-impedance gate; hence, loading on the resonant input circuit is minimised and gain is high. The local oscillator, however, feeds into the low-impedance source; this implies that power is required from the local oscillator, which may need buffering. One could reverse the inputs, thereby reducing the local oscillator power requirements, but that would reduce the gain. The output is taken from the drain with a tuned circuit selecting the sum or difference frequency.

Fig 5.8 shows a dual-gate MOSFET in a mixer circuit in which both inputs feed into high-impedance ports, but the dynamic range of these devices is somewhat limited. In this circuit, the G2 voltage equals that of the source. The local oscillator injection must be large, 1-3V p-p. Alternatively, G2 could be biased at approximately 25% of the supply voltage. Figs 6.53 and 6.55 (in Chapter 6) show examples of single-balanced mixers using FETs.

The circuit of **Fig 5.9** shows a single-balanced mixer, which is balanced with respect to the RF input. The circuit consists of a Dual-gate MOSFET (TR1), which amplifies the RF input and drives an RF current into the bipolar transistors TR1 and TR2. These two transistors achieve the mixing action and need to be reasonably well matched (a matched pair is ideal). The two bipolar transistors can be virtually any low to medium f_T devices. They should not have a very high f_T because they may tend to be unstable at VHF or UHF. For the MOSFET, virtually any Dual-gate FET can be used. The output inductor L1 was bifilar wound on a ferrite core and is resonant with C5 at the intermediate frequency. The local oscillator input transformer T1 was trifilar wound on a ferrite two-hole bead.

Bipolar ICs can also be configured as single-balanced or double-balanced mixers for use in the VHF range and below. ICs developed for battery-powered instruments such as portable and cellular telephones have very low power consumption and are used to advantage in QRP amateur applications. Often, a single IC contains not only a mixer but other functions such as a local oscillator and RF or IF amplifiers.

Monolithic technology relieves the home constructor of the task of matching components and adjusting bias, while greatly simplifying layout. Also, the results are more predictable, if not always up to the best obtainable with discrete components.

The NE602N mixer/local oscillator IC serves as an example. **Fig 5.10** shows a circuit of a mixer using an NE602A. A similar device is available under the number SA602A or SA612A.

Fig 5.11, the equivalent circuit of the IC and the following description of how it works were taken from reference [3]. The IC contains

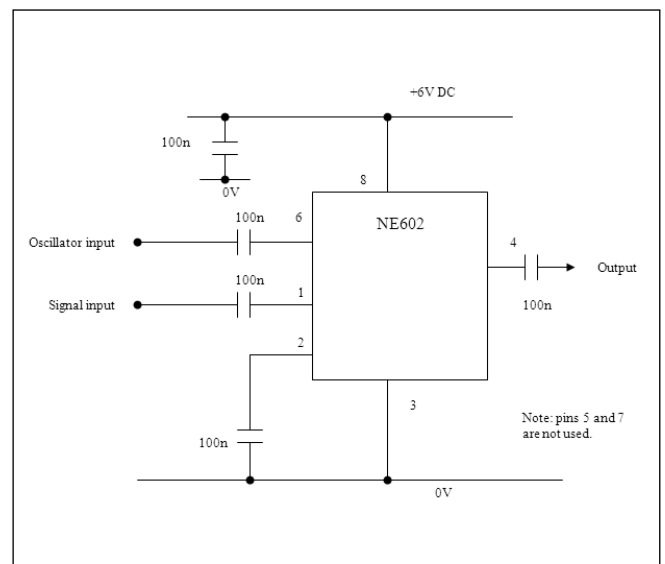

Fig 5.10: Circuit of Mixer using NE602

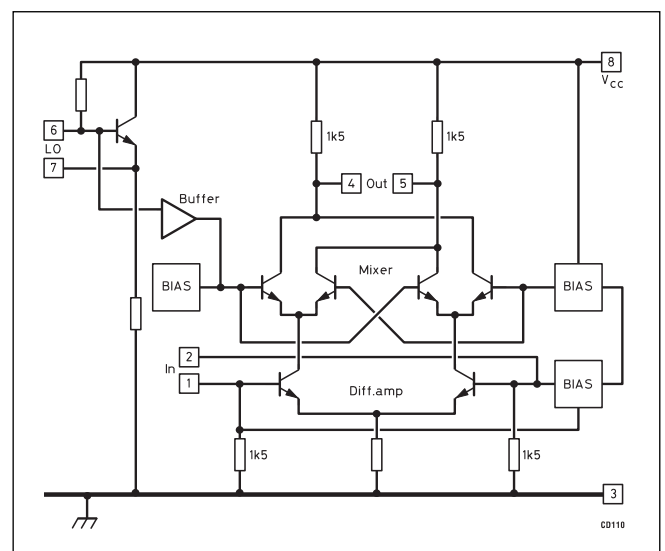

Fig 5.11: How the NE602N monolithic mixer/oscillator works is described in the text with reference to this equivalent circuit (Signetics RF Communications Handbook)

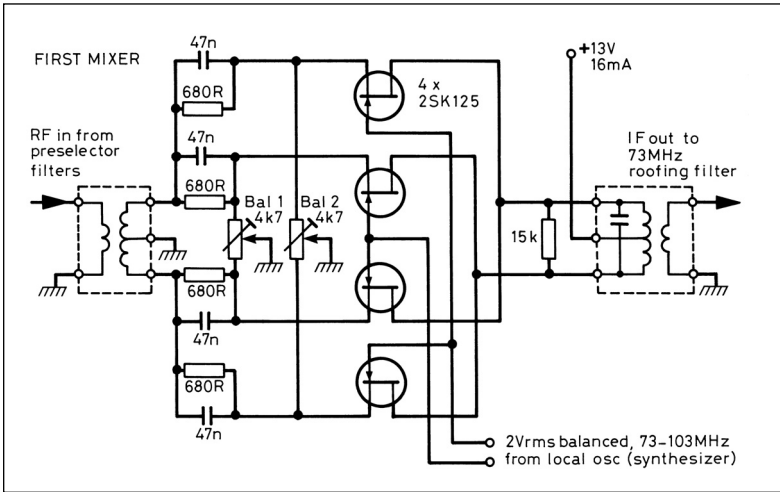

Fig 5.12: This four-JFET double-balanced mixer is as good as any seen in amateur receivers but does not have the problems of conversion loss, termination and high LO drive associated with diode ring mixers

a Gilbert cell (also called a transistor tree), an oscillator/buffer and a temperature-compensated bias network. The Gilbert cell is a differential amplifier (pins 1 and 2) which drives a balanced switching cell. The differential input stage provides gain and determines the noise figure and the signal-handling performance.

Performance of this IC is as follows. Its conversion gain is typically 18dB at 45MHz. The noise figure of 5dB is good enough to dispense with an RF amplifier in receivers for HF and below. The large-signal handling capacity is not outstanding, as evidenced by a third-order intercept point of only -15dBm (typically +5dBm referred to output because of the conversion gain). This restricts the attainable dynamic range to 80dB, well below the 100dB and above attainable with the preceding discrete-component mixers, but this must be seen in the light of this IC's low power consumption (2.4mA at 6V) and its reasonable price. The on-chip oscillator is good up to about 200MHz, the actual upper limit depending on the Q of the tuned circuit. The NE602 provides great flexibility on the input and output connections. Figures 6.88 and 6.89 (in Chapter 6) show various methods of connecting up the inputs and outputs of the NE602A.

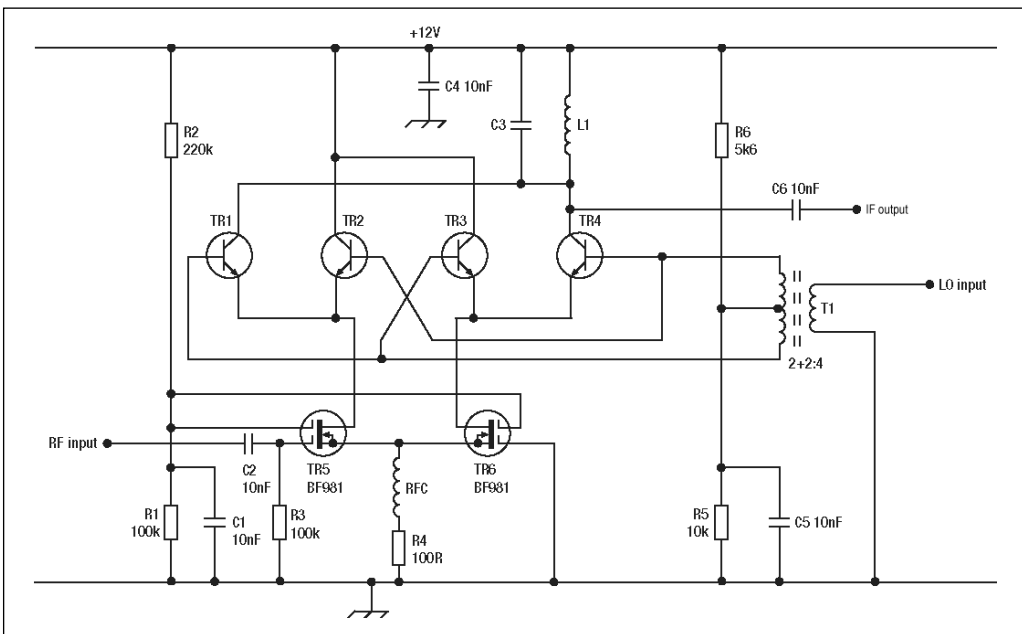

Fig 5.13: A double-balanced version of the mixer shown in Fig 5.9

The following double-balanced mixers can be used where low noise and good dynamic range must be combined with maximum suppression of unwanted outputs, eg in continuous-coverage receivers and multiband transmitters. Two different approaches are presented.

Fig 5.12 shows a double-balanced mixer using four JFETs. This is capable of high performance and is used in the Yaesu FT-1000 HF transceiver. The circuit offers some conversion gain and the local oscillator needs to supply little power as it feeds into the high-impedance gates.

Fig 5.13 shows a double-balanced mixer, which was derived from the single-balanced mixer in Fig 5.9. The circuit is designed on the principle of the Gilbert Cell. In this design however, the lower pair of transistors in the Gilbert Cell have been replaced with two dual-gate MOSFETs. The two MOSFETs do not operate as mixers but as amplifiers. In the prototype, matching was done by selection, finding two devices (from a batch of BF981s) that would operate at the same DC conditions when fitted into the circuit. However, pairs of MOSFETs in a single SMD package are available, eg Philips BF1102, and the use of these devices is recommended. The top four bipolar transistors achieve the mixing action in the same way as in the Gilbert Cell. The four transistors (TR1 to TR4) were contained within a CA3046 integrated circuit so they are very well matched. C3 and L1 were selected to be resonant at the intermediate frequency. T1 is similar to transformer T1 in Fig 5.9. The circuit gives extremely good balance, good noise figure, reasonable intermodulation performance, and a useful amount of gain.

The 3rd order intercept is about 25dB higher than the NE602, and the circuit is suitable as a front-end mixer in a medium performance HF receiver and would not require an RF amplifier. The circuit operates with a total supply current of about 20mA.

One of the advantages of the Gilbert Cell type of mixer is that the circuit will operate extremely well with a low level of local oscillator input. The circuit will give full performance with just 250mV p-p of local oscillator input. A square wave is best.

Further information and examples of mixer circuits can be found in chapters 6 and 7 of this handbook.

AMPLIFIERS

Amplifiers are an essential part of radio frequency electronics, and are used anywhere it is necessary to raise the power of a signal. Examples of this are described below.

- An RF amplifier is used on the antenna input of a VHF or UHF receiver. The input signals here may be extremely small, less than $1\mu\text{V}$.
- In a receiver, an IF amplifier is used to provide most of the overall gain.
- A transmitter contains a power amplifier to raise the power of the signal up to the level required for transmission. The output power may be many hundreds of watts.

The following section considers amplification of signals from just above audio frequency up to UHF. This includes examples of amplifiers for receiver input stages through to amplifiers which will transmit the normal power limit for UK amateurs (400W PEP), especially those which might be considered for home construction projects. Integrated circuits are available which require few extra components but they are often application-specific and so the performance is fixed. The advantage of using discrete components is that the performance of the circuit is under control of the designer. Therefore, included in this section are small-signal amplifiers with discrete semiconductors and ICs and power amplifiers with discrete semiconductors, hybrids (semi-integrated modules) and valves.

Intermediate Frequency (IF) Amplifiers

The primary requirement of an IF amplifier is to provide most of the gain needed in a receiver. In addition, it will be required to provide all (or most) of the gain control range. When choosing a device for use as an IF amplifier the main requirement is to choose one that will give a high gain. Other factors such as noise figure are usually secondary.

If discrete devices are to be used, the best choice is to use a bipolar transistor in common emitter configuration. **Fig 5.14** shows the circuit of an IF amplifier operating at 455kHz. For this frequency the transistor does not need to be a high frequency one. An audio type of transistor is adequate, and is also very cheap. The circuit shown operates at a current of about 1mA.

Even in common-emitter configuration, the maximum gain available from this circuit is limited, and if a large amount of gain is required in the IF strip then two or three such stages may be needed. The maximum gain in Fig 5.14 is limited by the following transistor parameters:

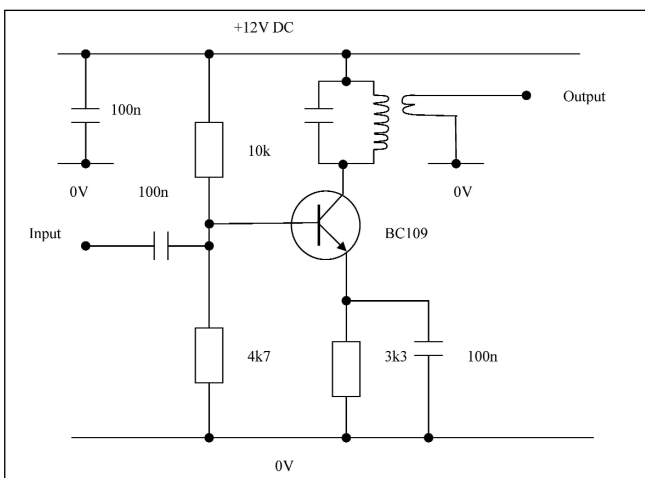

Fig 5.14: Transistor IF amplifier

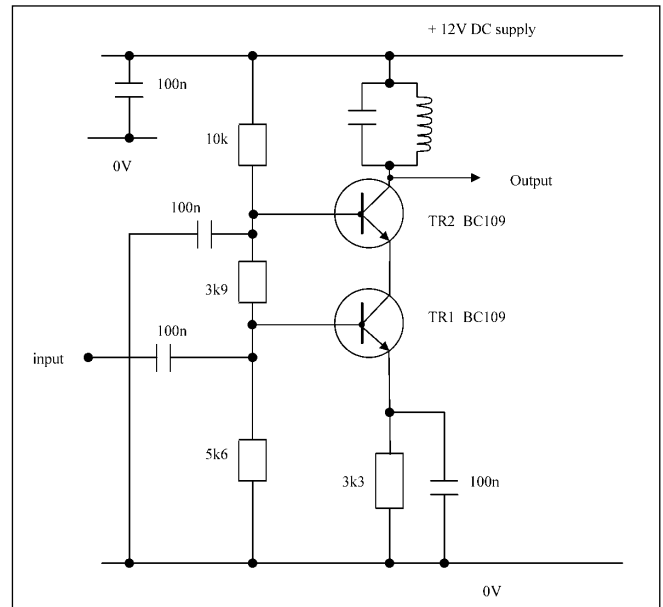

Fig 5.15: Cascode IF amplifier

- The output conductance (expressed in transistor h-parameters as h_{OE}).
- The reverse voltage transfer ratio (expressed in transistor h-parameters as h_{RE}).
- The miller capacitance (base - collector capacitance).

These can be overcome, and hence much more gain available, by using the cascode configuration as shown in **Fig 5.15**. This has only three extra components compared to Fig 5.14 but is able to provide much higher gain. Measurements on a prototype of this circuit showed a voltage gain of 2000 from the input of TR1 to the collector of TR2. This is an extremely useful IF amplifier that, in many cases, is able to provide all of the receiver IF gain.

A dual-gate MOSFET may be used as the amplifying element in an IF amplifier (**Fig 5.16**). Although the Dual-Gate MOSFET is configured internally rather like a cascode amplifier, it is not able to provide as much gain as Fig 5.15. The main virtue of the Dual-Gate MOSFET is that it has a good gain adjustment range. The circuit in Fig 5.16 is based upon a circuit from the BF981 data sheet, and will give about 50dB range of gain adjustment.

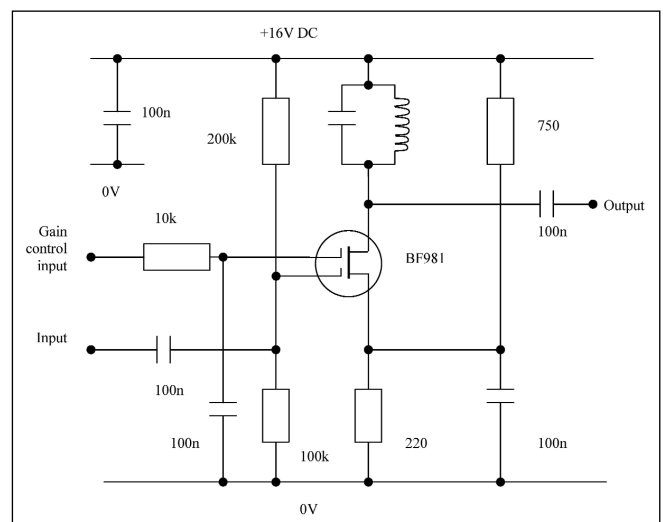

Fig 5.16: Dual gate MOSFET IF amplifier

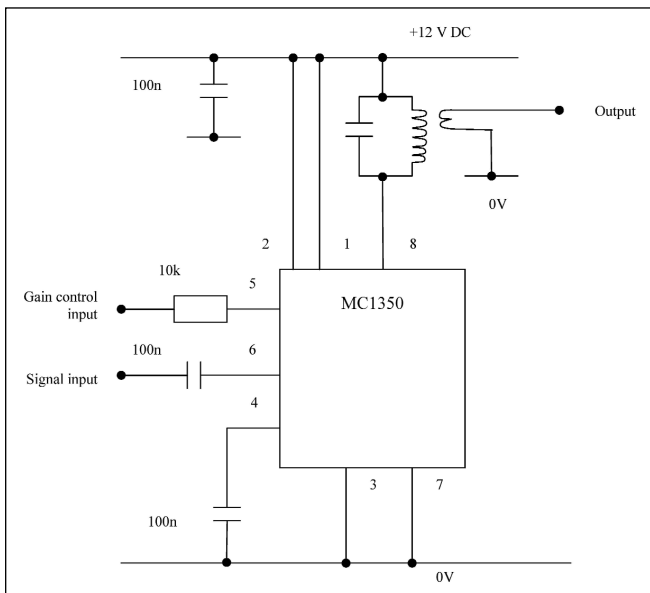

Fig 5.17: Circuit of IF amplifier using MC1350

Integrated circuits

In the past there were many application-specific integrated circuits which provided this function, but most of these are no longer manufactured, although they may still be available from surplus suppliers. One IC which is still generally available is the MC1350 (also available in a metal package as the MC1590).

The MC1350 provides the function of a high-gain amplifier, and has an input that can be used to control the gain. The gain control range is typically 68dB. Fig 5.17 shows the circuit of an IF amplifier employing an MC1350. The current consumption of the circuit is typically 14mA. If the gain control pin is left unconnected the IC will operate close to full gain.

It should be noted that any IF amplifier which has a high gain is prone to instability. This is because even a small amount of coupling from the output back to the input will provide a path for the amplifier to become unstable. For this reason, the layout of such a circuit is critical and it may require screening, particularly at higher IFs like 9MHz, 10.7MHz or 45MHz.

Methods of gain control

For reception of CW, SSB or AM signals, it is normal for the IF strip to have adjustable gain. The gain control may be derived from an AGC circuit, or it may be part of a manual gain control system or a combination of the two. The gain control is normally achieved by varying an input voltage (or current). There are many circuits that provide adjustment of gain. Ideally a circuit should provide a very wide range of gain adjustment, and the gain adjustment should be linear (ie have a constant dB per volt) over the full gain range.

Gain control using the MC1350 and a dual-gate MOSFET has already been described in this section. It should be noted that the gain control characteristic for the dual-gate FET (Fig 5.16) is not particularly linear, which may cause gain control problems if the dual-gate FET is included in an automatic gain control circuit.

A FET, when operated with zero drain-source bias voltage, acts as a resistor, the resistance value of which can be adjusted by the gate-source voltage. Examples of this are shown in Figs 5.18 and 5.19. In Fig 5.18 the FET is fitted in the emitter circuit of a transistor amplifier to adjust the transconductance of the amplifier. In Fig 5.19 the FET is connected across the collector load of the transistor to act as a variable load.

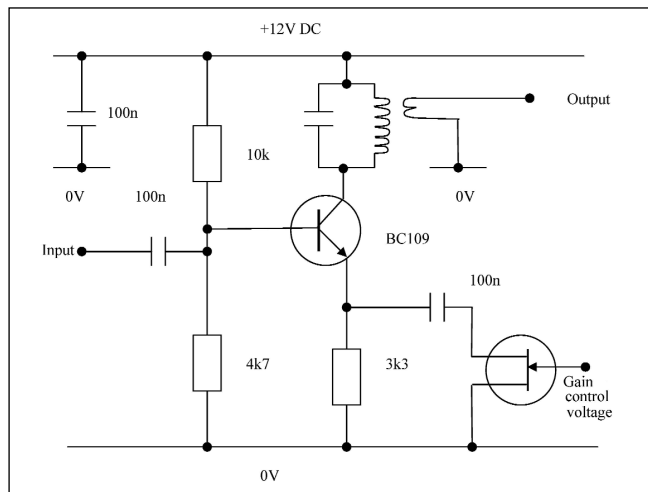

Fig 5.18: Transistor IF Amplifier with gain control applied to the transistor emitter

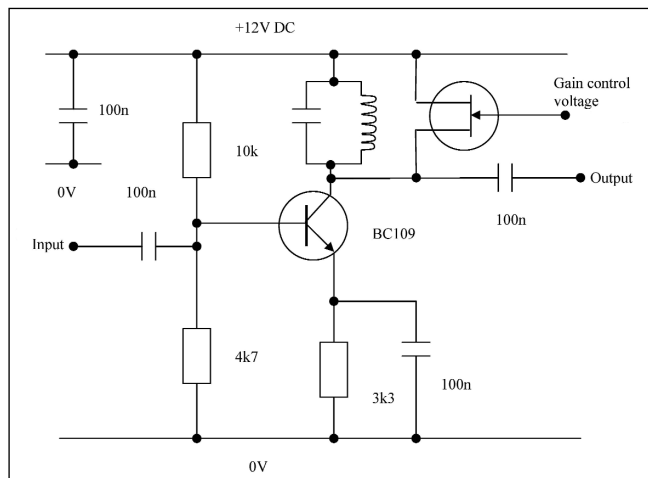

Fig 5.19: Transistor IF Amplifier with gain control applied to the collector load

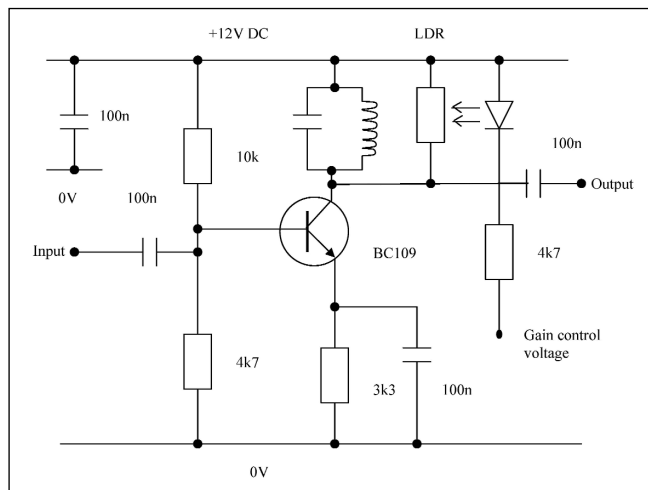

Fig 5.20: Transistor IF Amplifier with gain control using an LDR

In Fig 5.20 a light-dependant-resistor (LDR) is connected across the tuned circuit load of the transistor. The resistance of the LDR can be adjusted by varying the light falling on it from the LED. The LDR and the LED should be very close together and fitted inside a light-proof container. This circuit has been used by the author at

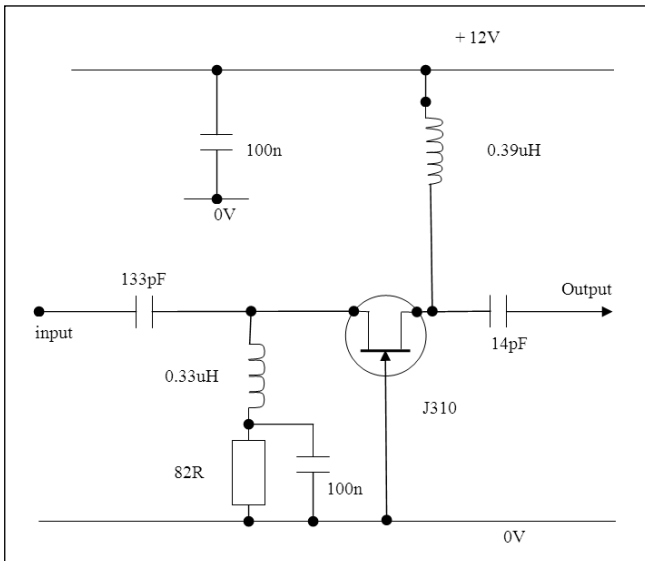

Fig 5.21: 50MHz FET amplifier

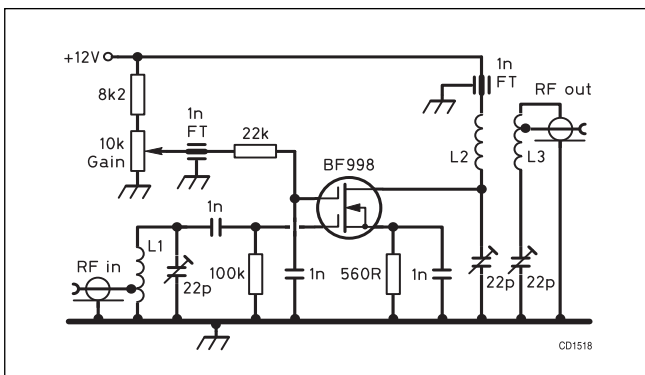

Fig 5.22: A 144MHz preamp using a BF998 SMD dual-gate MOSFET. L1: 5t 0.3mm tinned copper tapped 1t from earthy end, 10mm long, 6mm dia. L2, L3: 6t 1mm tinned copper 18mm long, 8mm dia. L3 tapped 1t from earthy end. L2, L3 mounted parallel, 18mm between centres

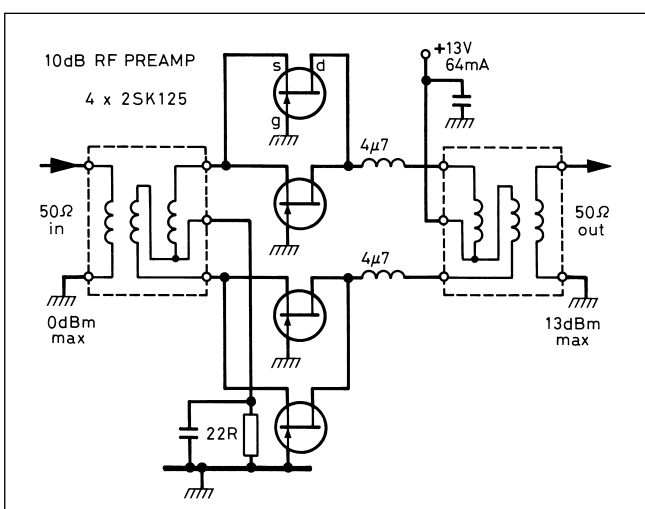

Fig 5.23: Four grounded-gate FETs in push-pull parallel running high drain currents give this RF stage of the Yaesu FT-1000 HF transceiver its excellent dynamic range, suppression of second-order intermodulation, and proper termination of preceding and following bandpass filters

455kHz, and gave a very smooth control of gain. The dynamic characteristics of the LDR give a fast attack / slow decay, which makes it particularly useful for use in an SSB receiver.

Radio Frequency (RF) Amplifiers

Low-level discrete-semiconductor RF amps

Discrete semiconductors are indicated when the function requires no more gain than that which can be realised in one stage, generally between 6 and 20dB, or when the required noise level or dynamic range cannot be met by an IC. In receiver input stages, ie ahead of the first mixer, both conditions may apply.

Modern discrete devices for use in RF amplifiers are extremely cheap, and the cost is therefore not a deciding factor in the decision on which device to use. Modern design of the first stage in a receiver demands filters rejecting strong out-of-band signals, a wide dynamic range, low-noise IF at VHF and above, and only enough gain to overcome the greater noise of an active first mixer or the conversion loss of a passive mixer, typically a gain of 10dB. Bipolar, field-effect and dual-gate MOSFET transistors can provide that. AGC can easily be applied to FET amplifiers, but the trend is to switch the RF amplifier off when not required for weak-signal reception.

In most of the following low-level RF circuits inexpensive general-purpose transistors such as the bipolar 2N2222A, FETs BF245A, J310, MPF102 and 2N3819, and the SMD dual-gate MOSFET BF998 can be used. However, substitution of one device by another or even by its equivalent from another manufacturer frequently requires a bias adjustment. For exceptional dynamic range, power FETs are sometimes used at currents up to 100mA. Similarly, for the best noise figure above 100MHz, gallium-arsenide FETs (GaAsFETs) are used instead of silicon types.

Fig 5.21 shows the circuit of a 50MHz amplifier using an FET in grounded-gate configuration. The circuit has networks on the input and output which provide impedance matching and tuning. The circuit operates between source and load impedances of 50 ohms.

The VHF amplifier in Fig 5.22 uses a dual-gate MOSFET.

Four FETs in a push-pull parallel grounded-gate circuit, Fig 5.23, are used in the RF amplifiers of some top-grade HF receivers. Push-pull operation reduces second-order intermodulation. Several smaller FETs in parallel approach the wide dynamic range of a power FET, and the source input provides, through a simple transformer, proper termination for the preselector filters.

Low-level IC Amplifiers

Monolithic integrated-circuit RF amplifiers come in a great variety, sometimes combined on one chip with other functions such as a mixer, detector, oscillator or AGC amplifier. A linear IC, though more expensive than its components in discrete form, has the advantage of well-specified performance in the proven PCB layouts given in the manufacturer's data sheet.

Some ICs are labelled 'general purpose', while others are optimised for a specific application. If intended for a VHF hand-portable FM transceiver, low power consumption might be a key feature, but linearity would be unimportant. However, an IC for fixed-station SSB use would be selected for good linearity, but the current consumption would be unimportant. Any potential user would do well to consult the data sheets or books on several alternative ICs before settling on any one. New devices are being introduced frequently and the price of older ones, often perfectly adequate for the intended function, is then reduced.

The following elaborates on a few popular devices, but only a fraction of the data sheet information can be accommodated here.

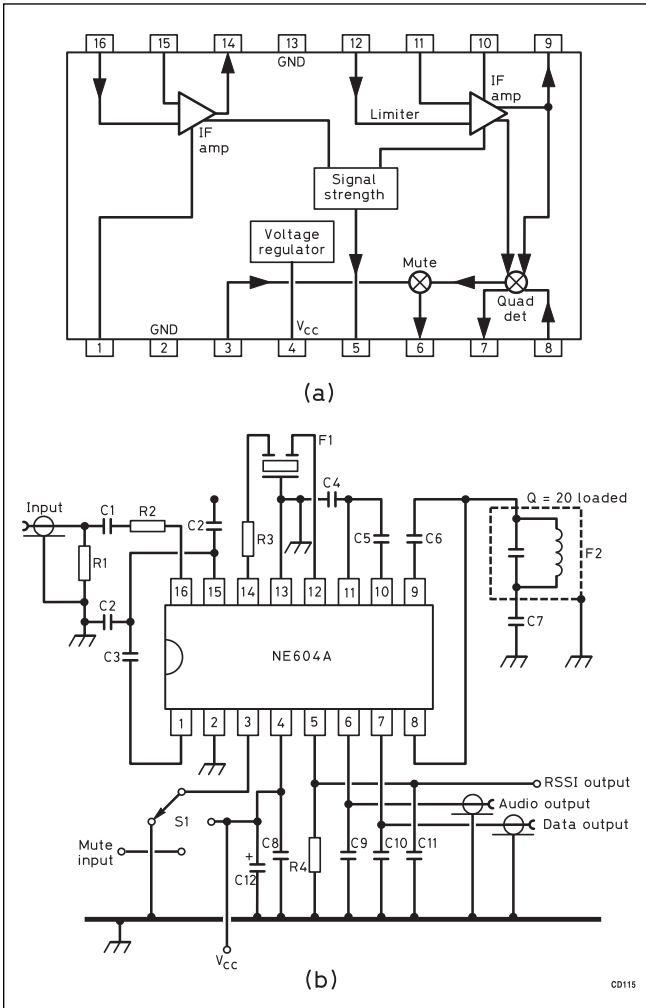

Fig 5.24: The NE604A FM receiver IC. (a) Internal block diagram. (b) External connections

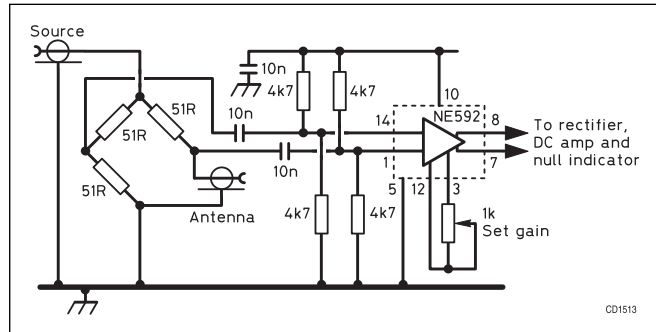

Fig 5.26: An inexpensive video amplifier IC, NE592N, can serve as a wide-band HF amplifier, as it does in G4COL's sensitive HF antenna bridge

The Philips-Signetics NE604AN contains all the active components for a NBFM voice or data receiver IF system [3] - see Fig 5.24.

It contains two IF amplifiers, which can either be cascaded or used at different frequencies in a double-conversion receiver, a quadrature detector, a 'received signal-strength indicator' (RSSI) circuit with a logarithmic range greater than 90dB, a mute switch (to cut the audio output when transmitting in simplex operation) and a voltage regulator to assure constant operation on battery voltages between 4.5V (at 2.5mA) and 8V (at 4mA). The IC is packaged in a 16-pin DIP. The operating temperature range of the NE604AN is 0 to 70°C.

The Toko TK10930V IC is an AM-FM 2nd IF-detector system in a 24-pin DIP. In it, the 10.7MHz 1st IF input is converted to a 455kHz 2nd IF and processed in separate AM and FM amplifier and detector channels to simultaneously provide audio output in each. AVC, RSSI and squelch circuitry is included. DC requirements are only 3V @ 4mA (FM only) or 7mA (both channels on). Applications are in portable scanners, airband and marine receivers but, unfortunately, there is no provision for SSB reception. Internal and external components are shown in Fig 5.25.

The Philips NE592N is an inexpensive video amplifier IC with sufficient bandwidth to provide high gain throughout the HF region. Its differential input (and output) enabled G4COL to use it, without a transformer, in a very sensitive antenna bridge in which both the RF source and the unknown impedance are earthed [4] The circuit is shown in Fig 5.26. For video response down to DC this IC requires both positive and negative supply voltages; for AC-only, ie RF, a single supply suffices, as explained for operational amplifiers later in this chapter.

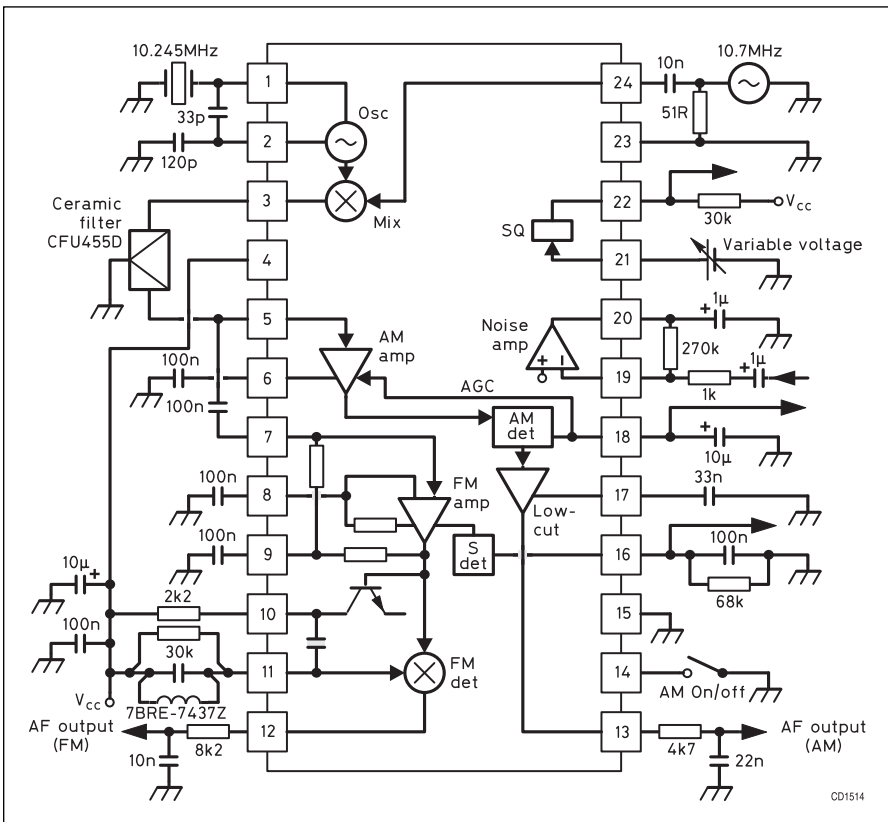

Fig 5.25: The Toko TK10930V IC comprises a mixer/LO from a 10.7MHz 1st IF to 455kHz and separate AM and FM IF-detector channels, plus auxiliary circuitry. Low drain, from a 3V battery, invites portable applications

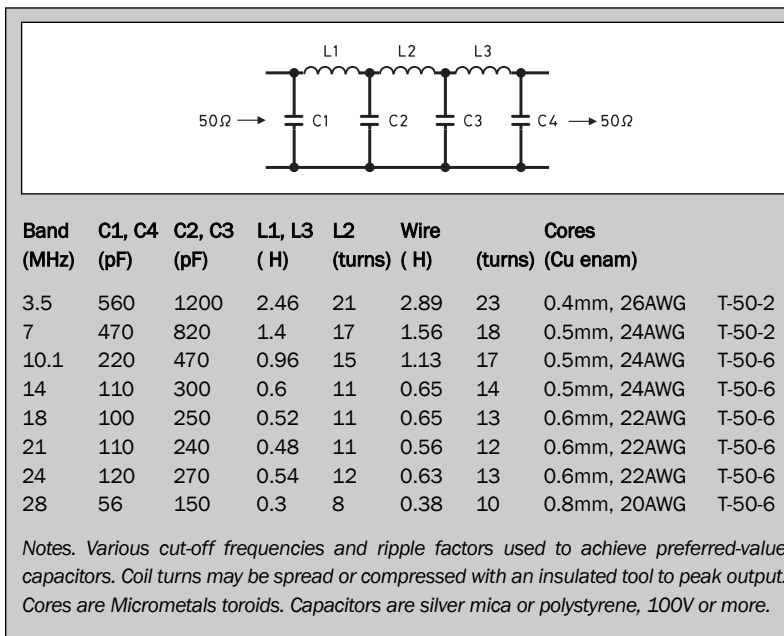

Table 5.3: Low pass output filters for HF amplifiers up to 25W

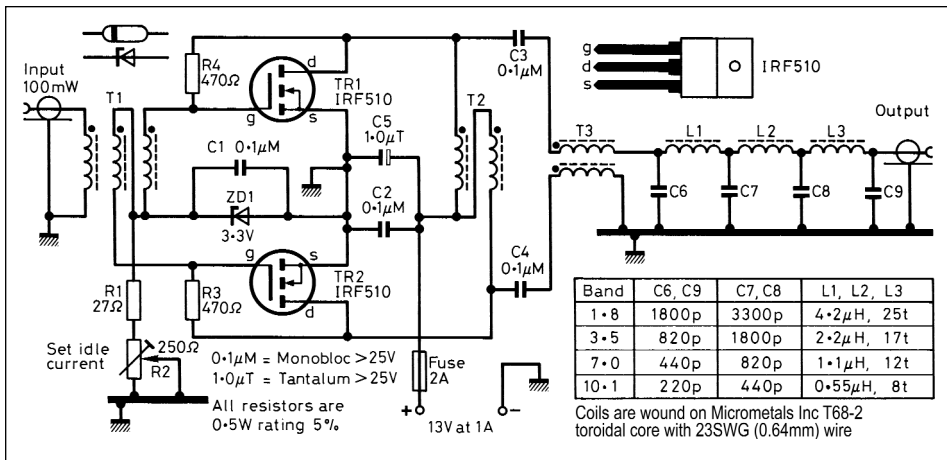

Fig 5.29: Circuit diagram of the 1.8-10.1MHz amplifier providing 5W CW or 6W PEP SSB using switching FETs. T1 comprises three 11t loops of 0.5mm enameled wire on FT50-43 core. T2, T3 are three 11t loops of 0.64mm enam wire on Amidon FT50-43. * Indicates start of winding

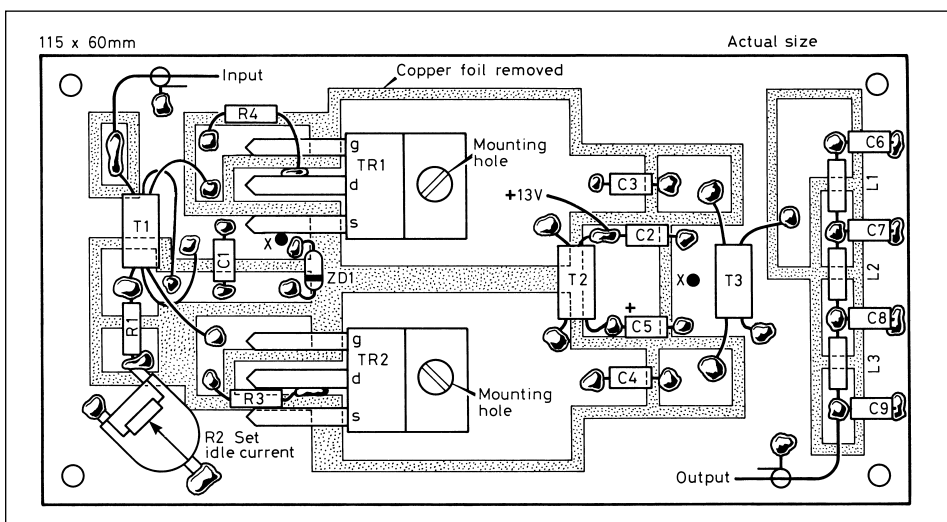

Fig 5.30: Layout of the 5W FET amplifier on double-sided PCB

amplifier, a proper harmonic filter for the band concerned must be used; without it even the third or fifth harmonic is capable of harmful interference. See Table 5.3.

Parasitic oscillations have also dogged experimenters. They can destroy transistors before they are noticed. A spectrum analyser is the professional way to find them but with patience a continuous coverage HF/VHF receiver can also be used to search for them. It is useful to key or modulate the amplifier to create a 'worst case' situation during the search. If found, a ferrite bead in each gate lead and/or a resistor and capacitor in series between each source and drain are the usual remedies. W1FB found negative feedback from an extra one-turn winding on the output transformer to the gate(s) helpful. VHF-style board layout and bypassing, where the back of the PCB serves as a ground plane, are of prime importance [7].

The first example is aimed at constructors without great experience; those following represent more difficult projects.

1.8-10.1MHz 5W MOSFET Amplifier

A push-pull broad-band amplifier using DMOS FETs and providing 5W CW or 6W PEP SSB with 0.1W of drive and a 13.8VDC supply has been described by Drew Diamond, VK3XU [8]. He used two inexpensive N-channel DMOS switching FETs which make useful RF amplifiers up to about 10MHz. This amplifier had a two-tone IMD of better than -30dBc (-35dBc typical) and, with the output filter shown in Fig 5.29, all harmonics were better than -50dBc. The amplifier should survive open or shorted output with full drive and remain stable at any load SWR.

The drain-to-drain impedance of the push-pull FETs is $2 \times 24 = 48\Omega$ so that no elaborate impedance transformation is needed to match into 50Ω . T3 serves as a balun transformer. T2 is a balanced choke to supply DC to the FETs. Negative RF feedback is provided by R3 and R4, stabilising the amplifier and helping to keep the frequency response constant throughout the range. The zener ZD1 is positioned against the heatsinks of TR1 and TR2 with a small blob of heatsink compound so that it tracks the temperature of the FETs, causing the bias voltage to go down when the temperature goes up. The amplifier enclosure must have adequate ventilation.

The complete amplifier, with an output filter for one band, can be built on a double-sided 115 x 60mm PCB.

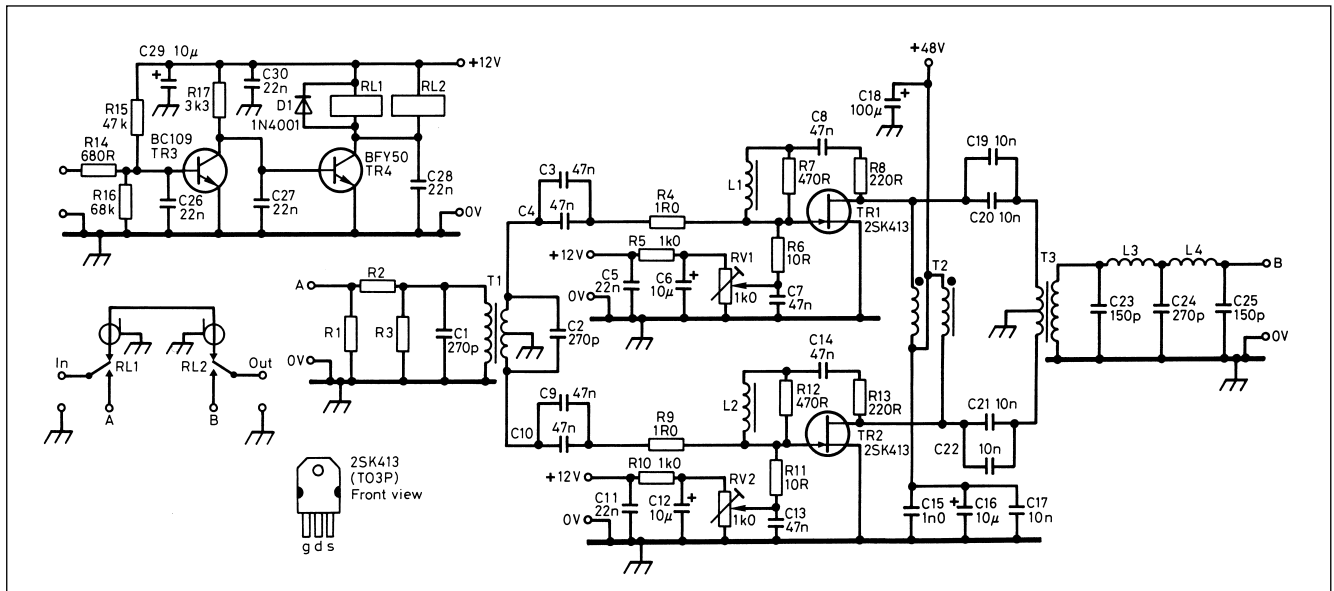

Fig 5.31: GOMRF's 100W HF linear amplifier uses inexpensive MOSFETs

For stability, the unetched 'ground plane' should be connected to the etched-side common/earth in at least two places marked 'X' in Fig 5.30. Drill 1mm holes, push wires through and solder top and bottom.

If multiband operation is required, the filter for the highest band should be accommodated on the amplifier board and kept in the circuit on all bands. Lower-frequency filters can then be mounted on an additional board. Polystyrene or silvered-mica capacitors should be used in the filters. Hard-to-get values can be made up of several smaller ones in parallel.

When setting up, with R2 at minimum resistance the desired no-signal current is 200-300mA. With 100mW drive and a 50Ω (dummy) load, the supply current should be about 1A. After several minutes of operation at this level and with suitable heatsinks, the latter should not be uncomfortably hot when touched lightly. While 100mW drive should suffice on the lower bands, up to 300mW may be needed at 10.1MHz, which is about the limit. Overdriving will cause flat-topping. With larger heatsinks and higher supply voltage, more output would be possible.

100W Multiband HF Linear

David Bowman, GOMRF, built and described [9] in great detail the design, construction and testing of his amplifier, complete with power supply, T/R switching and output filtering. With a pair of inexpensive 2SK413 MOSFETs, it permits an output of 100W from topband through 14MHz and somewhat less up to 21MHz. The RF part is shown in Fig 5.31.

A Linear 50MHz Amplifier

When selecting cheap switching FETs it is usually found that the drain is connected to the metal tab. Clamping this to ground with an insulating washer adds unwanted capacitance. The usual solution is to use two insulating washers, thus halving the capacitance. There is, of course, a slight reduction of the heat transfer efficiency.

PAOKLS found that useful 50MHz output could be obtained from a single IRF610 MOSFET in the circuit of Fig 5.32 [10]. With a 50V supply, the forward bias for Class AB operation was adjusted for an idling current of 50mA. A two-tone input of 0.2-0.3W then produced an output of 16W at a drain current of 0.5A. Third-order distortion was 24dB below either tone, not

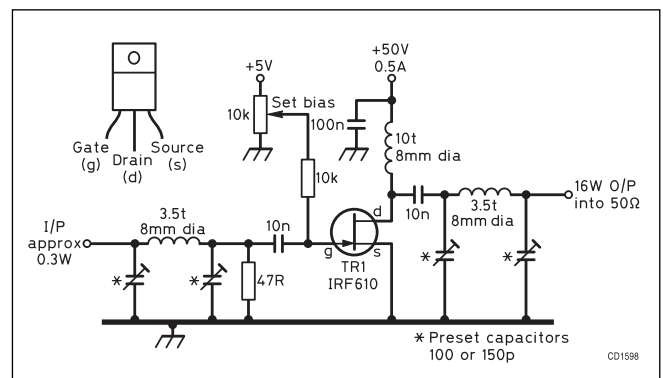

Fig 5.32: This 50MHz linear amplifier using an inexpensive switching MOSFET will deliver 16W output with less than 0.3W of drive

brilliant but adequate. Voice quality was reported to be good. On CW, the output exceeded 20W.

Best output loading of $(V_d)^2/2P_o = 78\Omega$ was obtained with another pi-network; while this provides only single-band matching, it reduces harmonics. The drain choke was made roughly resonant with the IRF610's drain-to-source capacitance of 53pF, so that the pi-coupler only has to match near-pure resistances.

As in a single-ended amplifier there is no cancellation of even harmonics and the second harmonic of 50MHz is in the 88-108MHz FM broadcast band, additional low-pass filtering is mandatory. Set up for 28MHz, this amplifier produced 30-40W CW; at this power level, with an insufficiently large heatsink, the MOSFET got very hot but it did not fail due to the inherent reduction of drain current mentioned above.

The difference between 28 and 50MHz output shows that 50MHz is about the upper limit for the IRF610.

Peter Frenning, OZ1PIF, has published a design [11] using eight IRF510 MOSFETs to produce 250W at 50MHz.

VHF Linear Amplifiers

For medium-power VHF linear amplifiers there is another cost-saving option. Because transistors intended for Class C (AM, FM or data) cost a fraction of their linear counterparts, it is tempting and feasible to use them for linear applications. If simple diode biasing alone is used, however, the transistors, such as the

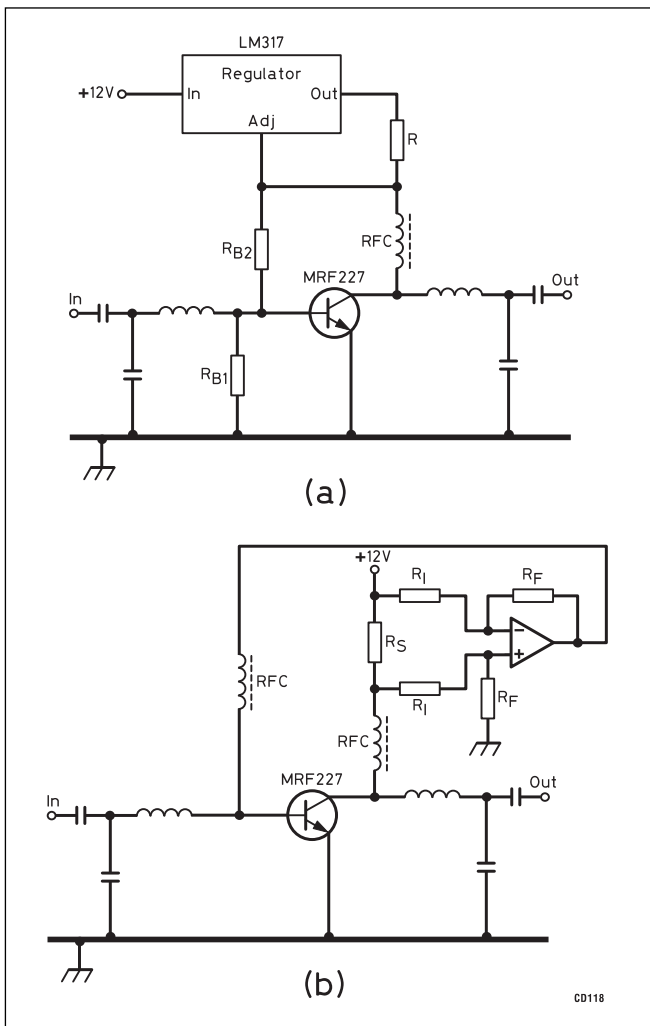

Fig 5.33: Two methods to prevent thermal runaway of medium-power VHF transistors designed for Class C only in linear amplifiers. (a) A supply current regulator. (b) An active biasing circuit (QST)

Part No.	Po (W)	Pin (mW)	Band (MHz)	Mode
M57735	19	200	50	lin
M57706L	8	200	145	-
M57719L	14	200	145	-
M57732L	7	20	145	lin
M57741UL	28	200	145	-
M57796L	7	300	145	lin
M67748L	7	20	145	lin
M67781L	40	300	145	-
M57704M	13	200	435	-
M57714M	7	100	435	-
M57716	17	200	435	lin
M57729	30	300	435	-
M57745	33	300	435	lin
M57788M	40	300	435	-
M57797MA	7	100	435	lin
M67709	13	10	435	lin
M67728	60	10	435	lin
M67749M	7	20	435	lin
M57762	18	1000	1296	lin

MRF227, go into thermal runaway. Two solutions to this problem were suggested in the ARRL lab for further experimentation [12]. Both methods preserve the advantages of a case earthed for DC.

The current-limiting technique of Fig 5.33(a) should work with any device, but is not recommended where current drain or power dissipation are important considerations. The approach is simply to use a power supply which is current limited, eg by a LM317 regulator, and to forward bias the transistor to operate in Class B. Forward bias is set by the values of RB1 and RB2.

The active biasing circuit of Fig 5.33(b) is not new but has not been much used by amateurs. The collector current of the transistor is sampled as it flows through a small-value sensing resistor RS; the voltage drop across it is amplified by a factor RV/Ri, the gain of the op-amp differential amplifier circuit. If the collector current goes up, the base voltage is driven down to restore the balance. The gain required from the op-amp circuit must be determined empirically. While experimenting, the use of a current-limiting power supply is recommended to avoid destroying transistors.

50-1296MHz power amplifier modules

Designing a multi-stage UHF power amplifier with discrete components is no trivial task. More often than not, individually tuned interstage matching networks are required. Duplicating even a proven design in an amateur workshop has its pitfalls. One solution, though not the least expensive, is the use of a sealed modular sub-assembly. These are offered by several semiconductor manufacturers, including Mitsubishi (see Table 5.4), Motorola and Toshiba.

For each band, there is a choice of output power levels, frequency ranges, power gain and class of operation (linear in Class AB for all modes of transmission or non-linear in Class C for FM or data modes only). All require a 13.8V DC supply, sometimes with separate external decoupling for each built-in stage, and external heatsinking.

In general, their 50Ω input provides a satisfactory match for the preceding circuitry, and a pi-tank (with linear inductor on the higher bands) is used for antenna matching and harmonic suppression. They are designed to survive and be stable under any load, including open- and short-circuit. As each model has its peculiarities, it is essential to follow data sheet instructions to the letter.

A 435MHz 15W mobile booster

PAOGMS built this 70cm power amplifier with RF VOX to boost the FM output from his hand-held transceiver to a respectable 15W for mobile use [13]. The circuit is shown in Fig 5.34. Its top half represents the amplifier proper, consisting of (right to left) the input T/R relay, input attenuator to limit input power to what the module requires for rated output, the power module with its power lead decoupling chokes (ferrite 6 x 3mm beads with three turns of 0.5mm diameter enamelled copper wire) and bypass capacitors (those 0.1μF and larger are tantalum beads with their negative lead earthed; lower values are disc ceramics, except for the 200pF which is a feedthrough type). The output tank (two air trimmers and a 25mm long straight piece of 2mm silvered wire) feeds into the output T/R relay. Both relays are National model RH12 shielded miniature relays not designed for RF switching but adequate for UHF at this power level. The choke between the relay coils is to stop RF feedback through the relays.

Table 5.4: Some Mitsubishi RF power modules. All operate on 12V mobile systems, but those rated over 25W cannot be supplied from a 5A (cigar lighter) circuit and generally require forced air cooling of the heat sink. Suitable for SSB only if marked 'lin' (Extracted from a 1998 Mainline Electronics pamphlet)

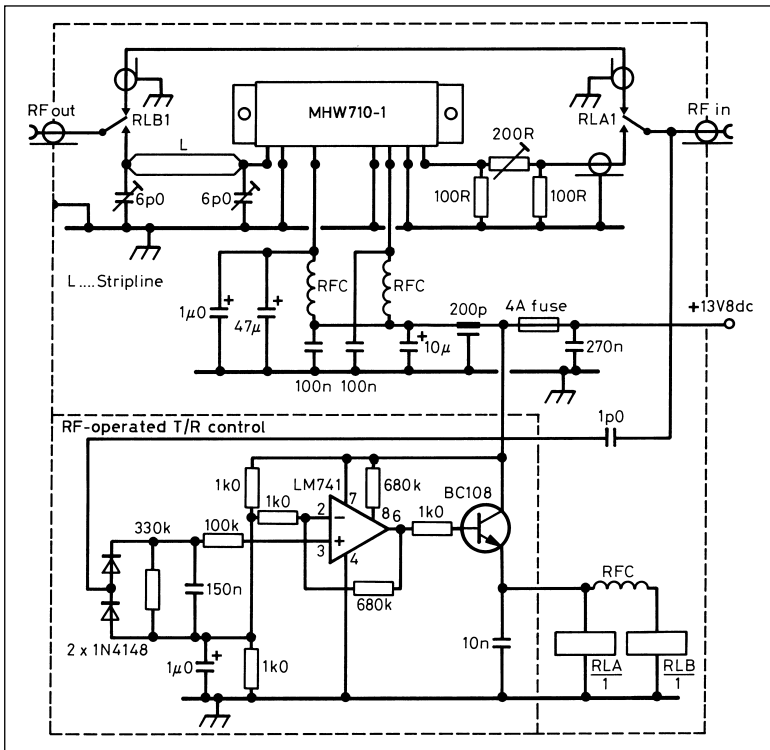

Fig 5.34: The PA0GMS 15W 435MHz mobile booster. The original MHW710-1 power module is obsolete, but model M57704M (different pin-out) is suitable

The relays are activated by what is sometimes mis-named a VOX (voice-operated control) but is in fact an RF-operated control. Refer to the diagram at the bottom of Fig 5.34. A small fraction of any RF drive applied to the amplifier input is rectified and applied to the high-gain op-amp circuit here used as a comparator. Without RF input, the op-amp output terminal is at near-earth potential, the NPN transistor is cut off, and the relays do not make, leaving the amplifier out of the circuit as is required for receiving. When the operator has pressed his PTT (push-to-talk) switch, RF appears at the booster input, the op-amp output goes positive, the transistor conducts, and the relays make, routing the RF circuit through the booster.

This kind of circuit is widely used for bypassing receiving amplifiers and/or inserting power boosters in the antenna cable when transmitting; at VHF or UHF, this is often done to make up for losses in a long cable by placing these amplifiers at masthead or in the loft just below. Though not critical, the 1pF capacitor may have to be increased for lower frequencies and lower power levels, and reduced for higher frequencies and higher input power. The NPN transistor must be capable of passing the coil currents of the relays. While not an issue with 0.5W in and 15W out, at much higher power levels proper relay sequencing will be required.

No PCB is used for the amplifier proper. It is built into a 110 x 70 x 30mm tin-plate box, Fig 5.35. The module is bolted through the bottom of the box to a 120 x 70mm heatsink which must dissipate up to

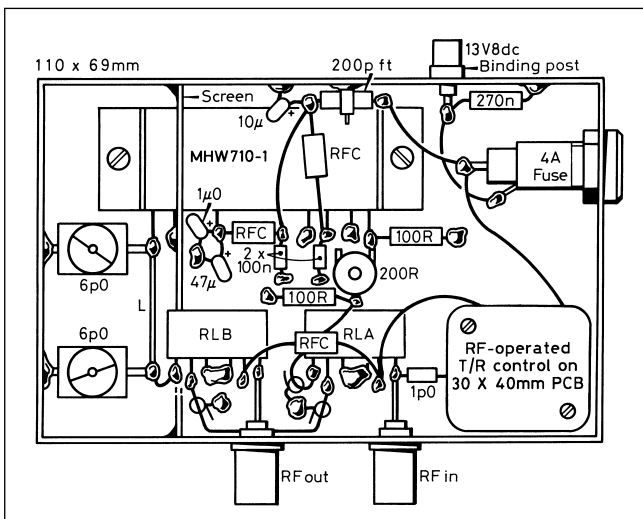

Fig 5.35: Construction of the PA0GMS 15W 435MHz mobile booster. The RF-operated T/R control is a sub-assembly on a PCB

30W. Heat transfer compound is used between the module and the box and also between the box and the heatsink; both must be as flat as possible. Care is required when tightening the bolts as the ceramic substrate of the module is brittle. The other components are soldered in directly. The RF-operated relay control is a sub-assembly mounted on a 40 x 30mm PCB.

Adjustments are simple. Set the input attenuator to maximum resistance and the two air trimmers to half-mesh. Apply 0.6 or 0.7W input from the hand-held and verify that both relays make. A few watts of output should be generated at this stage. Adjust the two air trimmers to peak the output, then reduce the input attenuation until the output reaches 15W with a supply current of about 3A. This completes the adjustment. Harmonics were found to be -60dBc and intermodulation -35dBc.

PIN Diode T/R Switching

If the same antenna is to be used both for transmitting and receiving, change-over switching is required. This normally is accomplished by means of an electro-mechanical relay. If, however, the receiver must function as quickly as possible after the end of each

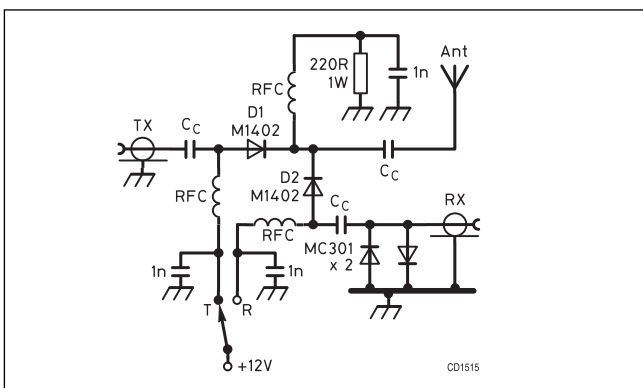

Fig 5.36: Solid-state antenna switch using pin diodes for transmitter power up to 25W. The diode numbers are Mitsubishi models. Typical data are:

Frequency (MHz)	Isolation Tx to Rx (dB)	Insertion loss (dB)
29	40	0.3
50	39	0.3
144	39	0.3
220	38	0.4
440	36	0.5

The off-state isolation can be improved by providing a DC return when the diodes are reverse-biased. Connect a resistor (1 - 10k) across both 1n capacitors

Type	Base	Heater (V)	(A)	Pa (W)	Va (V)	Vg2 (V)	Fmax full rating (MHz)	Po max (W)	Socket
QQV02-6*	B9A (Fig 5.48)	6.3	0.8	2 x 3	275	200	500	5	B9A
		12.6	0.4						
QQV03-10*	B9A (Fig 5.48)	6.3	0.8	2 x 5	300	200	225	12.5	B9A
6360		12.6	0.4						
QQV03-20A*	B7A (Fig 5.72)	6.3	1.3	2 x 10	600	250	200	48	B7A
6252		12.6	0.65				600	20	
QQV06-40A*	B7A (Fig 5.72)	6.3	1.8	2 x 20	750	250	200	90	B7A
5894		12.6	0.9				475	60	
PL519/40KG6A	B9D (Fig 5.73)	42	0.3	35	2500	275	21	100	B9D
40KD6A	9RJ (Fig 5.73)								
EL519/6KG6A	B9D (Fig 5.73)	6.3	2.0	35	2500	275	21	100	B9D
6KD6A	9RJ (Fig 5.73)								
813	5BA	10	5.0	125	2500	750	30	250	5BA
4X150A	B8F	6.0	2.6	150	1250	200	165	195	2m SK600A
QV1-150A	Special						500	140	70cm SK620A
2C39A	Disc seal	6.3	1.05	100	1000	-	2500	40	500MHz special
7289								17	2500MHz
3CX100A5									
4CX250B	B8F	6.0	2.6	250	2000	400	500	300 (AB1)	2m SK600A
QE61-250	Special							390 (C)	70cm SK620A

Table 5.5: Ratings of some commonly used power amplifier valves. The * denotes a double tetrode with built-in neutralisation

transmission, as in high-speed packet operation, the release plus settling time of a relay, several milliseconds, restricts the data throughput and solid-state switching is indicated.

This is done by using PIN diodes as switches. When such a diode is 'biased on' by (typically) 50mA DC in its pass direction, its RF resistance is almost as low as that of closed relay contacts; when biased by a voltage in the opposite direction, it acts like a pair of open relay contacts.

To separate bias and RF circuits, bias is applied through RF chokes; capacitors pass only the RF. Fig 5.36 shows the basic circuit. The resistor limits the bias current and provides the 'off bias' voltage. The back-to-back diodes limit the transmitter power reaching the receiver under fault condition. The insertion loss and isolation (the fraction of transmitter power getting through to the receiver) achievable with discrete components is tabulated.

At UHF and above, less-effective chokes and stray capacitances limit performance. For the 432 and 1296MHz bands, there are hybrid modules available containing the whole circuit optimised for one band.

Valve Power Amplifiers

Warning - all valve power amplifiers use lethal voltages. Never reach into one before making sure that the HT is off and HT filter capacitors discharged; do not rely on bleeder resistors - they can fail open-circuit without you knowing it. If there is mains voltage in the amplifier enclosure, be sure that the plug is pulled before working on it.

Virtually all current factory-made HF amplifiers up to the normal power limit (400W = +26dBW PEP output in the UK) are solid state. The same is true for VHF and UHF equipment up to about 100W. For home construction, however, the criteria are different. Power transistors are expensive and can be instantly destroyed, even by minor abuse; some components, such as a transformer for a 50V/20A power supply, are not easy to find at a reasonable price. By contrast, valves do tolerate some abuse and those who consider the search for inexpensive components an integral part of their hobby find rich pickings at rallies and surplus sales. Table 5.5 gives rough operating conditions (PEP or CW) for some valves still popular with amateur constructors.

All high-power amplifiers require an RF-tight enclosure and RF filtering of supply and control leads coming out of them. Doing otherwise invites unnecessary interference with any of the electronic devices in your and your neighbours' homes.

Technical alternatives will now be considered and several economical ways of implementing them are given. All are single-stage linear amplifiers intended to boost the output power of a transceiver.

Choosing valves

The first choice concerns the valves themselves; one to four of these must be capable of delivering the desired power gain and output power at the highest intended operating frequency at reasonable filament and anode voltage and, where required, control-grid bias and screen-grid voltage. The availability and cost of the valve(s), valve socket(s), power supply transformer(s) and anode tank capacitor will frequently restrict the choice.

Test frequency	3.7MHz
Anode voltage	710V
Anode current (no signal)	20mA
Anode current (max signal)	162mA*
Control-grid bias	5V set for minimum cross-over distortion on 'scope
Average RF current into 70 ohms	1.15A
PEP RF output	185W*
PEP RF input	20W* (estimated)
Anode load resistance	2k (estimated)
Valve inter-electrode capacitances	
Anode to all other electrodes	22pF measured cold
Anode to control grid	2.5pF from data sheet
Control grid to cathode	20pF measured cold
* At this level, the solder of the anode caps would melt even with fan cooling! It is reassuring to know that overdriving the amplifier will not distort the output, ie cause splatter, or instantly destroy the valve but it obviously is not for routine operation.	

Table 5.6: Two-tone measurements by G4DTC on his PL519 grounded-grid amplifier with fan cooling

Some valves of interest to the economy-minded constructor of HF amplifiers were not designed for radio transmitters at all but to drive deflection yokes and high-voltage transformers at the horizontal sweep frequency in CTV receivers; accordingly, the manufacturers' data sheets are not much help to the designer of RF circuits. However, amateurs have published the results of their experiments over the years. For the popular (originally Philips) pentode PL519, which can produce 100W PEP at HF and reduced output up to 50MHz, some information is given in **Tables 5.5 and 5.6**. With fan cooling, long valve life can be expected.

Another HF favourite is the (originally GE) 'beam power' tetrode type 813. This valve, first made more than 50 years ago, is now available new from Eastern European and Chinese manufacturers at a reasonable price but there are good buys available in used American JAN-813s. These can be tested by comparison with an 813 which is known to be good in the type of amplifier and at the approximate frequency and ratings of intended usage. This valve is rated at 100W (CCS) anode dissipation (125W ICAS); with 2500V on the anode and forced-air cooling a single valve can provide an output of 400W PEP, but it is better practice to use two valves in push-pull or parallel to produce this output without such cooling. One disadvantage is the requirement for a hefty filament transformer; each 813 requires 10V at 5A, AC or DC. A detailed description of a 400W HF amplifier using two 813s appeared in reference [14].

For VHF and UHF, two series of valves stand out. One comprises the double-tetrodes (originally Mullard, later Philips) QQV02/6, QQV03/10, QQV03/20A and QQV06/40A; the other is a family of (originally Eimac) 'external-anode' valves including the beam-power tetrodes 4X150A and 4CX250B. Though expensive when new, these valves can be found 'good used' as a result of the military and avionics practice of replacing valves on a 'time expired' rather than 'when worn out' basis. Test them as recommended for the 813 above.

On 144MHz and below, a QQV06/40A in Class AB1 can produce up to 100W PEP on a plate voltage of 1kV. In 432MHz operation, the efficiency will be lower, but 60W can be obtained with reduced input; fan cooling will increase the life expectancy of valves run near their dissipation limits.

External-anode valves can produce 'maximum legal' power on VHF and UHF but they always require forced-air cooling and the construction of the amplifiers is mechanically demanding. Convertible surplus equipment with them is not often found but several proven designs are detailed in the *RSGB VHF/UHF Handbook*.

For high power in the 23 and 13cm bands, the disc-seal triode 2C39A is universally used. Amplifier designs appear in the *RSGB Microwave Handbook*. The Russian Gi7bt and similar valves are also very popular and inexpensive and some designs can be found in *Microwave Projects 2* (RSGB), by Andy Barter, G8ATD.

Valve configuration

There are three different ways to drive an amplifier valve: tuned grid, passive grid and grounded grid; the advantages and disadvantages of each are shown in **Table 5.7**. One disadvantage listed for tuned-grid amplifiers is the requirement for neutralisation; this may need explanation. The anode-to-control-grid capacitance within a valve feeds part of the RF output back to the control grid. The impedance of that capacitance decreases with increasing frequency, until at some frequency the stage will oscillate.

In tetrodes and pentodes, the RF-earthed screen grid reduces the anode-to-control-grid capacitance, so that most are stable on the lower HF bands but, depending on valve characteristics and external circuitry, oscillation will become a problem at some frequency at which the valve otherwise works well.

Tuned grid, Class AB1

Advantages

- (a) Low driving power.
- (b) As there is no grid current, the load on the driver stage is constant.
- (c) There is no problem of grid bias supply regulation.
- (d) Good linearity and low distortion.

Disadvantages

- (a) Requires tuned grid input circuit and associated switching or plug-in coils for multiband operation.
- (b) Amplifier must be neutralised.*
- (c) Lower efficiency than Class AB2 operation.

Tuned grid, Class AB2

Advantages

- (a) Less driving power than passive grid or cathode-driven operation.
- (b) Higher efficiency than Class AB1.
- (c) Greater power output.

Disadvantages

- (a) Requires tuned grid input circuit.
- (b) Amplifier must be neutralised*.
- (c) Because of wide changes in input impedance due to grid current flow, there is a varying load on the driver stage.
- (d) Bias supply must be very 'stiff' (have good regulation).
- (e) Varying load on driver stage may cause envelope distortion with possibility of increased harmonic output and difficult with TVI.

Passive grid

Advantages

- (a) No tuned grid circuit.
- (b) Due to relatively low value of passive grid resistor, high level of grid damping makes neutralising unnecessary.
- (c) Constant load on driver stage.
- (d) Compact layout and simplicity of tuning.
- (e) Clean signal with low distortion level.
- (f) Simple circuitry and construction lending itself readily to compact layout without feedback troubles.

Disadvantages

- (a) Requires higher driving power than tuned grid operation.

Cathode driven

Advantages

- (a) No tuned grid circuit.
- (b) No neutralising (except possibly on 28MHz).
- (c) Good linearity due to inherent negative feedback.
- (d) A small proportion of the driving power appears in the anode circuit as 'feedthrough' power.

Disadvantages

- (a) High driving power - greater than the other methods.
- (b) Isolation of the heater circuit with ferrite chokes or special low-capacitance-wound heater transformer.
- (c) Wide variation in input impedance throughout the driving cycle causing peak limiting and distortion of the envelope at the driver.
- (d) The necessity for a high-C tuned cathode circuit to stabilise the load impedance as seen by the driver stage and overcome the disadvantage of (c).

* Neutralisation is built into the QQV-series of double tetrodes.

Table 5.7: Advantages and disadvantages of tuned-grid, passive-grid and grounded-grid PA valves

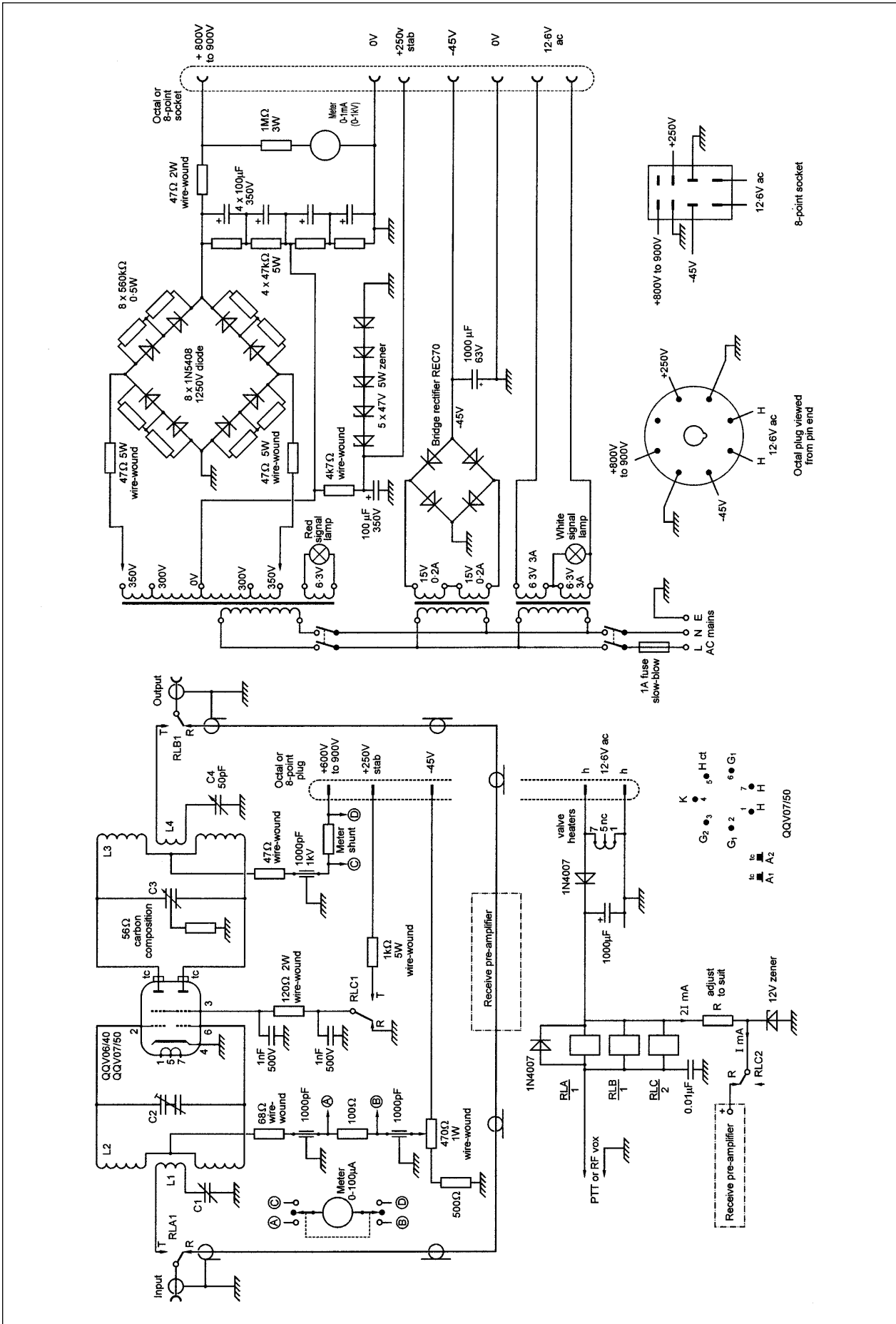

Fig 5.37: A tuned-grid double-tetrode linear VHF amplifier and its power supply. 50, 70 and 144MHz versions differ in tuned circuit values only

Neutralisation

One remedy is neutralisation, which is the intentional application of feedback from the anode to the grid, outside the valve and in opposite phase to the internal feedback, so that the two feedback voltages will cancel. Neutralisation was universally required in tuned-grid triode amplifiers but recent trends have been to avoid the need for neutralisation. Generally, neutralisation is not required in amplifiers using passive-grid tetrodes or pentodes and grounded-grid triodes, tetrodes or pentodes, or external-anode tetrodes with flat screen grids and hence extremely small anode-to-control-grid capacitance. Exceptions are tuned-grid push-pull amplifiers with the QQV-series double-tetrodes which have the neutralisation capacitors built-in.

A Double-tetrode Linear VHF Amplifier

The amplifier shown in Fig 5.37 [15] is popular for 50, 70 and 144MHz; differences are in tuned circuit values only. With 1.5-3W PEP drive, 70-90W PEP output can be expected, depending on frequency. For CW and SSB, convection cooling is sufficient. For FM or data, the input power should be held to 100W or a little more with fan cooling. The anodes should not be allowed to glow red. The circuit exemplifies several principles with wider applicability. Typical values for this particular amplifier are given below in *(italics)*.

- It is a push-pull amplifier, which cancels out even harmonics; this helps against RFI, eg from a 50MHz transmitter into the FM broadcast band.
- It also makes neutralisation easier; the neutralisation achieved by capacitors from each control grid to the anode of the other tetrode (here within the valve envelope) is frequency independent as long as both grid and anode tuned circuits are of balanced construction and well shielded from each other.
- Control-grid bias (-30V) is provided from a fairly low-impedance source set for a small (35mA) 'standing' (ie zero signal) current between 10 and 20% of the peak signal current (250mA); the latter must be established by careful adjustment of the RF input. This is different from Class C amplifiers (in CW, AM and FM transmitters) with large (tens of kilohms) grid resistors which make the stage tolerant of a wide range of drive levels.
- The screen-grid voltage is stabilised; this also differs from the practice in Class C amplifiers to supply the screen through a dropping resistor from the anode voltage; that

could cause non-linear amplification and excessive screen-grid dissipation in a Class AB1 linear amplifier. Where very expensive valves are used, it is wise to arrange automatic removal of the screen-grid voltage in case of failure of the anode voltage; a valve with screen-grid but no anode voltage will not survive long. This can be combined with the function of relay RLC, which removes screen-grid voltage during receive periods, thereby eliminating not only unnecessary heat generation and valve wear but also the noise which an 'idling' PA sometimes generates in the receiver.

- Tuning and coupling of both the grid and plate tanks of a linear amplifier should be for maximum RF output from a low but constant drive signal. This again differs from Class C amplifiers, which are tuned for maximum 'dip' of the DC anode current. This amplifier circuit has been used on 50, 70 and 144MHz. Table 5.8 gives tuned-circuit data.
- Note the cable from the power supply to the amplifier: the power supply has an eight-pin chassis socket and the amplifier an eight-pin chassis plug; the cable has a plug on the power supply end and a socket on its amplifier end. Disconnecting this cable at either end never exposes dangerous voltages.

Grounded-grid 200W Linear HF Amplifier

The amplifier shown in Fig 5.38 was designed by G3T50 to boost the output of HF transceivers in the 5 to 25W class by about 10dB [16]. It uses a pair of TV sweep valves in parallel; originally equipped with the American 6KD6, the European EL519 or PL519 are equivalent and the pin numbers in the diagram are for them. The choice depends only on the availability and price of the valves, sockets and filament supply; the 6KD6 and EL519 have a 6.3V, 2A filament, while the PL519 requires 42V, 0.3A. The two filaments can be connected in series, as shown in the diagram, or in parallel. Table 5.9 provides details of some other components. A few of the design features are:

- It may seem that the pi-input filter, L1 and C1-C11, is superfluous; it is if the driving stage is a valve with a resonant anode circuit. The cathodes do not, however, present to a wide-band semiconductor driver a load which is constant over the RF cycle, causing distortion of the signal in the driver stage. This is avoided by inclusion of a tuner which does double duty as an impedance transformer from

Band	C1	L1	L2	C2	C3	L3	L4
144MHz	30pF	1½t, 8mm ID, 2mm dia insulated	2 + 2t, 8mm ID, 2mm dia, length 28mm, gap 8mm	20 + 20pF	12 + 12pF	2 + 2t, 16mm ID, 3mm dia Cu tubing, length 25mm, gap 8mm	1t 16mm ID, 2mm dia well-insulated
70MHz	50pF	2t 9.5mm ID, 0.9mm dia insulated	8 + 8t, 9.5mm ID, 1.2mm dia	20 + 20pF	20 + 20pF	8 + 8t 25mm ID, 1.2mm dia	1t 25mm ID, 1.2mm dia well-insulated
50MHz	50pF	2t 15mm ID, 0.8mm dia insulated 7cm to C1 twisted	3 + 3t 15mm ID, 0.8mm dia	50 + 50pF	30 + 30pF	6 + 6t 15mm ID, 1mm dia	2t 15mm ID, 0.8mm dia well-insulated, 10cm to C4 twisted

C2 and C3 are split stator. C4 is 50pF

Table 5.8: Tuned circuits for the double-tetrode linear VHF amplifier. Note that there is no logical progression to the coils from band to band because the data were taken from the projects of three different amateurs. Using a 'dip' oscillator, ie before applying power to the amplifier, all tuned circuits should, by stretching or squeezing the air-wound coils, be pre-adjusted for resonance in the target band, so that there is plenty of capacitor travel either side of resonance

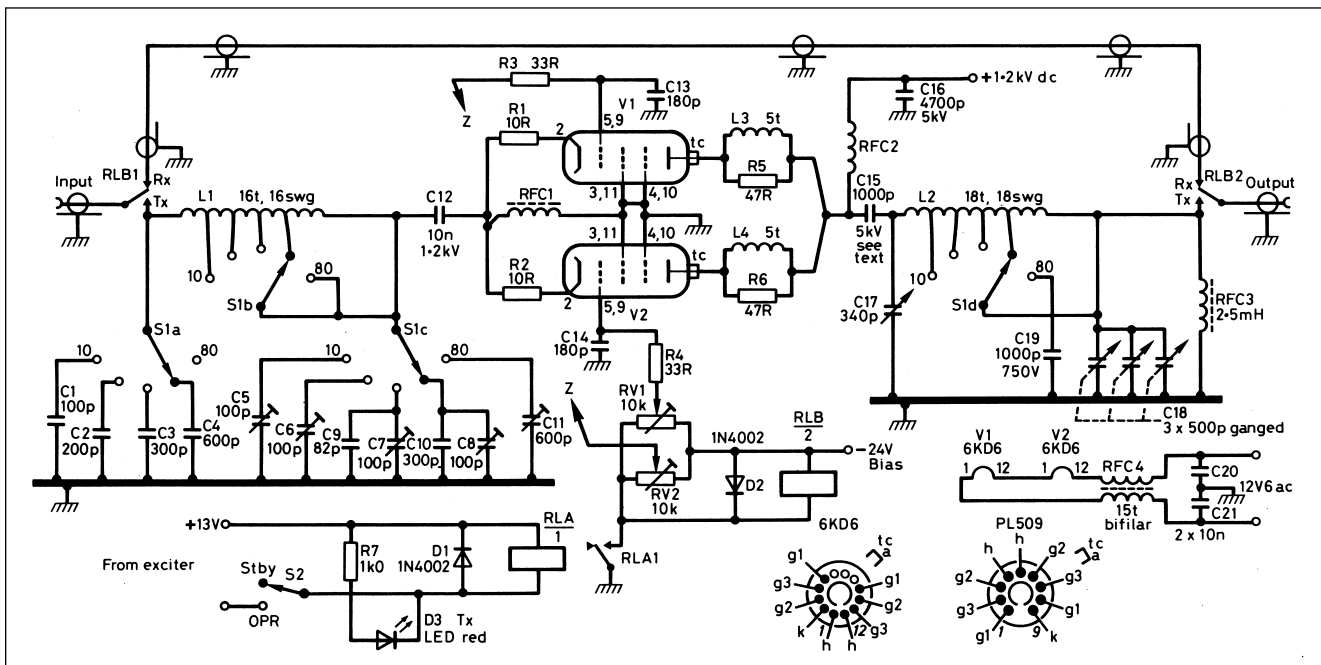

Fig 5.38: A grounded-grid 200W linear HF amplifier built by G3TSO, mostly from junk-box parts. No screen grid supply is required

50Ω. The pi-filter is sufficiently flat to cover each band without retuning, but not to include any of the WARC bands.

- The valves, with all three grids earthed, ie connected as zero-bias triodes and without RF drive, would remain within their dissipation rating. With separately adjustable bias to each control grid, however, it is possible not only to reduce the no-signal anode current to the minimum necessary for linearity (20mA each valve) but also, by equalising the two

idling currents, assure that the two valves will share the load when driven. This is particularly important when valves with unequal wear or of different pedigree are used together. It makes the purchase of 'matched pairs' unnecessary.

- When valves are operated in parallel, the wires strapping like electrodes together, along with valve and socket capacitances, will resonate at some VHF or UHF frequency. If the valves have sufficient gain at that frequency, the stage may burst into parasitic oscillation, especially at the modulation peaks when power gain is greatest. Even in a single-valve or push-pull stage this can happen as HF tuning capacitors are short-circuits at VHF or UHF. In this amplifier, several precautions are taken. Both pins of each screen and suppressor grid are earthed to chassis by the shortest possible straps; the control grids are by-passed to earth through C13 and C14 in a like manner; some valve sockets have a metal rim with four or more solder lugs for that purpose. Carbon stopper resistors R5 and R6 are used to lower the Q of parasitic resonances. Mere resistors would dissipate an intolerable fraction of the output, especially on the highest operating frequency where the valve's anode-to-earth capacitances are a large part of the total tank capacitance and carry high circulating currents; small coils L3 and L4 are therefore wound on the stoppers. These coils are dimensioned to have negligible impedance at all operating frequencies but not to short the stopper resistor at a potential parasitic frequency. The resistor with coil is called a parasitic suppressor and considerable experimentation is often required; it is sometimes possible to get away without them.
- The insulation between valves' cathodes and filaments was never made to support RF voltages. The cathodes of grounded-grid amplifiers, however, must be 'hot' for RF; the filaments, therefore, should be RF-insulated from earth; this is the purpose of RFC4. The bypass capacitors C20 and C21 prevent RF getting into the power supply. The filament wiring, including that on RFC4, must carry the filament current (4A for two parallel EL519 filaments) without undue voltage drop. Figure-8 hi-fi speaker cable is suitable.

L1	16t, 1.6mm Cu-tinned, 25mm dia, 51mm long, taps at 3, 4, 6, 10t
L2	18t, 1.2mm Cu-tinned, 38mm dia, first 4t treble spaced, remainder double spaced. Taps at 3, 4, 6, 9t
L3, 4	5t 1.2mm Cu-enam wound on 47 1W carbon resistor
RFC1	40t 0.56mm Cu-enam on ferrite rod or toroid ($\mu = 800$)
RFC2	40t 0.56mm Cu-enam on 12mm dia ceramic or PTFE former
RFC3	2.5mH rated 500mA
RFC4	15 bifilar turns, 1.2mm Cu-enam on ferrite rod 76mm 9.5mm dia
C1-4, 9, 10, 12-14	Silvered mica
C5-8	Compression trimmers
C15	Two 500p ceramic TV EHT capacitors in parallel
C16	4.7n, 3kV or more ceramic, transmitting type or several smaller discs in parallel
C18	3 x 500p ganged air-spaced variable (ex valved AM receiver)
C19	1n 750V silver mica, transmitting type or several smaller units in parallel
R1, 2	10R 3W carbon (beware of carbon film resistors, which may not be non-inductive)
RV1, 2	10k wirewound or linear-taper cermet potentiometer
Coaxial cable	RG58

Table 5.9: Components for the G3TSO grounded-grid 200W linear HF amplifier

- The anode tuning capacitor C17 is a 'difficult' component. Not only must it be rated for more than twice the off-load DC plate voltage (3.5mm spacing), but its maximum capacitance should be sufficient for a loaded Q of 12 at 3.5MHz, while its minimum capacitance should be low lest the Q gets too high on 29MHz. If an extra switch section S1e is available, C17 can be 100pF maximum with fixed capacitors of 100pF and 250pF respectively being switched across it on 7 and 3.5MHz. These fixed capacitors must be rated not only for high RF voltages (3.5kV) but also for the high circulating currents in a high-Q tuned circuit. Several low-capacitance silvered-mica capacitors in parallel will carry more current than one high-capacitance unit of the same model. High-voltage, high-current 'transmitting type' ceramic capacitors are available. Beware of Second World War surplus moulded mica capacitors; after more than 50 years, many have become useless.
- The anode choke requires special attention. It must have sufficient inductance to isolate the anode at RF from its power supply. Even at the lowest operating frequency (3.5MHz) and its self-resonance(s) (the inductance resonating with the distributed capacitance within the coil) must not fall within 20% or so of any operating frequency lest circulating current destroys the choke. Self-resonances can be revealed by shorting the choke and coupling a dip meter to it. The traditional approach was to divide the choke winding into several unequal series-connected segments, thereby moving their individual self-resonance frequencies into the VHF region; one problem is that surrounding metallic objects cause in situ resonances to differ from those measured on the bench. Another approach, adopted in RFC2, is to use one single-layer winding with a self-inductance not much greater than the whole pi-filter inductor (L2). Its self-resonance is well above the highest operating frequency (29MHz) but one has to accept that at 3.5MHz a substantial fraction of the tank current flows through RFC2 rather than through L2. At full output, the choke will get very hot; that is why it should be wound on a ceramic or PTFE rod or tube; also,

the wire connections should be mechanically well made so that melting solder will not cause failure. The bypass capacitor (C16) must be rated for the RF current through RFC2 (and also for more than the DC supply voltage).

- The bandswitch in the pi-output filter (S1d) must withstand high RF voltages across open contacts and high circulating currents through closed contacts; above the 100W level, ceramic wafers of more-than-receiver size are required.
- The 'safety choke' (RFC3) is there to 'kill' the HT supply (and keep lethal voltages off the antenna!) in case the capacitor (C15) should fail short-circuit. RFC3 must be wound of sufficiently thick wire to carry the HT supply's short-circuit current long enough to blow its fuse.
- At HF, coaxial relays are unnecessary luxuries; power switching relays with 250VAC/5A contacts are adequate. In some relays with removable plastic covers all connections are brought out on one side with fairly long wires running from the moving contacts to the terminals. If so, remove the cover and those long wires and solder the (flexible) centre conductors of input and output coaxial cables directly to the fixed ends of the moving contact blades. In this amplifier, one relay, RLB, switches both input and output. This requires care in dressing RF wiring to avoid RF feedback from output to input. A relay with three changeover contacts side by side is helpful; the outer contact sets are used for switching, the spare centre set's three contacts are earthed as a shield. The foolproof way is to use two relays.

Passive-grid 400W Linear HF Amplifier

PAOFRI's Frinear-400 is shown in Fig 5.39 [17]. It has several interesting features. It was based on Dick Thornely's, G2DAF, patent for a RF grounded screen grid and DC grounded control grid linear amplifier with the screen voltage derived from the input RF signal.

- Being a passive-grid amplifier, most of the input power is dissipated in a hefty carbon resistor. The voltage across it is applied to the control-grids of the valves and, considering

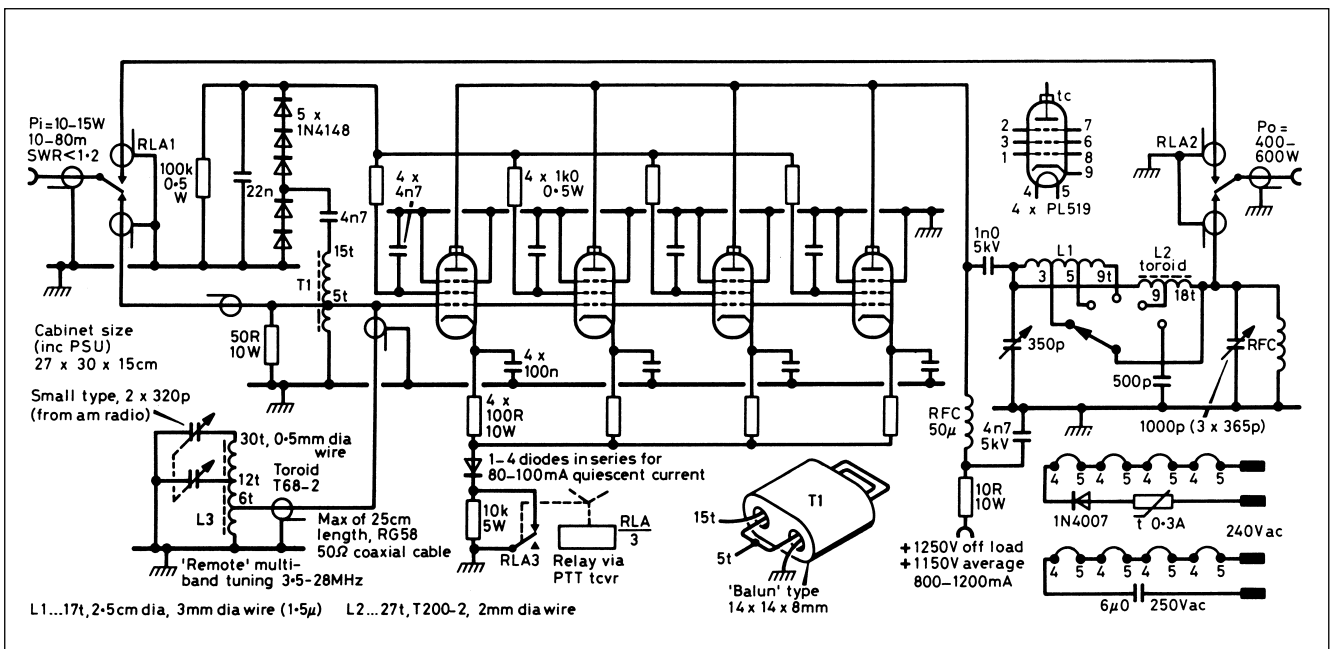

Fig 5.39: A passive-grid 400W linear HF amplifier, the PAOFRI Frinear. Screen-grid voltage is derived from the RF input and no grid bias supply is required

the low value of the resistor (50 or 68 ohms), one might expect this arrangement to be frequency-independent. However, the capacitances of the four grids, sockets and associated wiring add up to about 100pF which is only 55Ω at 29MHz! This capacitance must be tuned out if what is adequate drive on 3.5MHz is to produce full output on the higher-frequency bands. PAOFRI does this with a dual-resonant circuit (L3 and ganged tuning capacitors) similar to the well-known E-Z-Match antenna tuner; it covers 3.5-29MHz without switching.

- The screen grids in this amplifier are neither at a fixed high voltage nor at earth potential but at a voltage which is proportional to the RF drive. To that end, the RF input is transformed up 3:1 in T1, rectified in a voltage doubler and applied to the four bypassed screen grids through individual resistors. This method is consistent with good linearity.
- Control-grid bias is not taken from a mains-derived negative supply voltage but the desired effect, reducing the standing current to 20-25mA per valve, is obtained by raising the cathodes above earth potential. The bias voltage is developed by passing each cathode current through an individual 100Ω resistor and the combined currents through as many forward-biased rectifier diodes as are required to achieve a total standing current of 80-100mA. The individual cathode resistors help in equalising the currents in the four valves. During non-transmit periods the third contact set (RLA3) on the antenna changeover relay opens and inserts a large (10kΩ) resistor into the combined cathode current, which is reduced to a very low value.
- The pi-filter coil for 3.5 and 7MHz is wound on a powdered-iron toroid which is much smaller than the usual air-core coil. This is not often seen in high-powered amplifiers due to the fear that the large circulating current might saturate the core and spoil the intermodulation performance but no distortion was discernible in a two-tone test [18].
- In Fig 5.33, the 42V filaments of the four valves and a capacitor are shown series connected to the 230V mains. This 0.3A chain is the way these valves were intended to be used in TV sets and it does save a filament transformer, but this method is not recommended for experimental apparatus such as a home construction project. Besides, a 6μF 250VAC capacitor is neither small nor inexpensive, and generally not available from component suppliers. Also, with lethal mains voltage in the amplifier chassis, the mains plug must be pulled every time access to the chassis is required and after the change or adjustment is made there is the waiting for filaments to heat up before applying HT again. It is much safer and more convenient to operate the filaments in parallel on a 42V transformer (3 x 12.6 + 5V will do), or to use EL519 valves in parallel, series-parallel or series on 6.3, 12.6 or 25.2V respectively.

DC AND AF AMPLIFIERS

This section contains information on the analogue processing of signals from DC (ie zero frequency) up to 5kHz. This includes audio amplifiers for receivers and transmitters for frequencies generally between 300 and 3000Hz as well as auxiliary circuitry, which may go down to zero frequency.

Operational Amplifiers (Op-amps)

An op-amp is an amplifier which serves to drive an external network of passive components, some of which function as a feedback loop. They are normally used in IC form, and many different types are available. The name operational amplifier comes from their original use in analogue computers where they were used

to perform such mathematical operations as adding, subtracting, differentiating and integrating.

The response of the circuit (for example the gain versus frequency response) is determined entirely by the components used in the feedback network around the op-amp. This holds true provided the op-amp has sufficient open-loop gain and bandwidth.

Why use IC op-amps rather than discrete components? Op-amps greatly facilitate circuit design. Having established that a certain op-amp is adequate for the intended function, the designer can be confident that the circuit will reproducibly respond as calculated without having to worry about differences between individual transistors or changes of load impedance or supply voltages. Furthermore, most op-amps will survive accidental short-circuits of output or either input to earth or supply voltage(s). General-purpose op-amps are often cheaper than the discrete components they replace and most are available from more than one maker. Manufacturers have done a commendable job of standardising the pin-outs of various IC packages. Many devices are available as one, two or four in one DIL package; this is useful to reduce PCB size and cost but does not facilitate experimenting.

Many books have been written about the use of op-amps; some of these can be recommended to amateur circuit designers as most applications require only basic mathematics; several titles are found in the Maplin catalogue. In the following, no attempt is made to even summarise these books, but some basics are explained and a few typical circuits are included for familiarisation.

The symbol of an op-amp is shown in Fig 5.40. There are two input terminals, an inverting or (-) input and a non-inverting or (+) input, both with respect to the single output, on which the voltage is measured against earth or 'common'. The response of an op-amp goes down to DC and an output swing both positive and negative with respect to earth may be required; therefore a dual power supply is used, which for most op-amps is nominally ±15V.

Where only AC (including audio) signals are being processed, a single supply suffices and blocking capacitors are used to permit the meaningless DC output to be referred to a potential halfway between the single supply and earth established by a resistive voltage divider. In application diagrams, the power supply connections are often omitted as they are taken for granted.

To understand the use of an op-amp and to judge the adequacy of a given type for a specific application, it is useful to define an ideal op-amp and then compare it with the specifications of real ones. The ideal op-amp by itself, open loop, ie without external components, has the following properties:

- Infinite gain, ie the voltage between (+) and (-) inputs is zero.
- Output is zero when input is zero, ie zero offset.
- Infinite input resistance, ie no current flows in the input terminals.
- Zero output resistance, ie unlimited output current can be drawn.
- Infinite bandwidth, ie from zero up to any frequency.

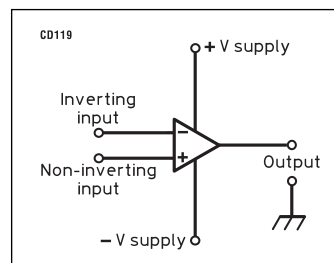

Fig 5.40: Symbol of an operational amplifier (op-amp)

No real op-amp is ideal but there are types in which one or two of the specifications are optimised in comparison with general-purpose types, sometimes at the expense of others and at a much higher price. The most important of these specifications will now be defined; the figures given will be those of the most popular and least expensive of general-purpose op-amps, the $\mu\text{A}741\text{C}$. Comparative specifications for a large variety of types are given in the Maplin catalogue.

Maximum ratings

Values which the IC is guaranteed to withstand without failure include:

- Supply voltage: $\pm 18\text{V}$.
- Internal power dissipation: 0.5W .
- Voltage on either input: not exceeding applied positive and negative supply voltages
- Output short-circuit: indefinite.

Static electrical characteristics

These are measured at DC ($V_s = \pm 15\text{V}$, $T = 25^\circ\text{C}$).

- Input offset voltage (V_{oi}): the DC voltage which must be applied to one input terminal to give a zero output. Ideally zero. 6mV max.
- Input bias current (I_b): the average of the bias currents flowing into the two input terminals. Ideally zero. 500nA max.
- Input offset current (I_{os}): the difference between the two input currents when the output is zero. Ideally zero. 200nA max.
- Input voltage range (V_{cm}): the common-mode input, ie the voltage of both input terminals to power supply common. Ideally unlimited. $\pm 12\text{V}$ min.
- Common-mode rejection ratio (CMRR): the ratio of common-mode voltage to differential voltage to have the same effect on output. Ideally infinite. 70dB min.
- Input resistance (Z_i): the resistance 'looking into' either input while the other input is connected to power supply common. Ideally infinite. $300\text{k}\Omega$ min.
- Output resistance (Z_o): the resistance looking into the output terminal. Ideally zero. 75Ω typ.
- Short-circuit current (I_{sc}): the maximum output current the amplifier can deliver. 25mA typ.
- Output voltage swing ($\pm V_o$): the peak output voltage the amplifier can deliver without clipping or saturation into a nominal load. $\pm 10\text{V}$ min ($R_L = 2\text{k}\Omega$).
- Open-loop voltage gain (A_{ol}): the change in voltage between input terminals divided into the change of output voltage caused, without external feedback. $200,000$ typ, $25,000$ min. ($V_o = \pm 10\text{V}$, $R_L = 2\text{k}\Omega$).
- Supply current (quiescent, ie excluding I_b) drawn from the power supply: 2.8mA max.

Dynamic electrical characteristics

- Slew rate is the fastest voltage change of which the output is capable. Ideally infinite. $0.5\text{V}/\mu\text{s}$ typ. ($R_L = 2\text{k}\Omega$).
- Gain-bandwidth product: the product of small-signal open-loop gain and the frequency (in Hz) at which that gain is measured. Ideally infinite. 1MHz typ.

Understanding the gain-bandwidth product concept is basic to the use of op-amps at other than zero frequency. If an amplifier circuit is to be unconditionally stable, ie not given to self-oscillation, the phase shift between inverting input and output must be kept below 180° at all frequencies where the amplifier has gain. As a capacitive load can add up to 90° , the phase shift within most op-

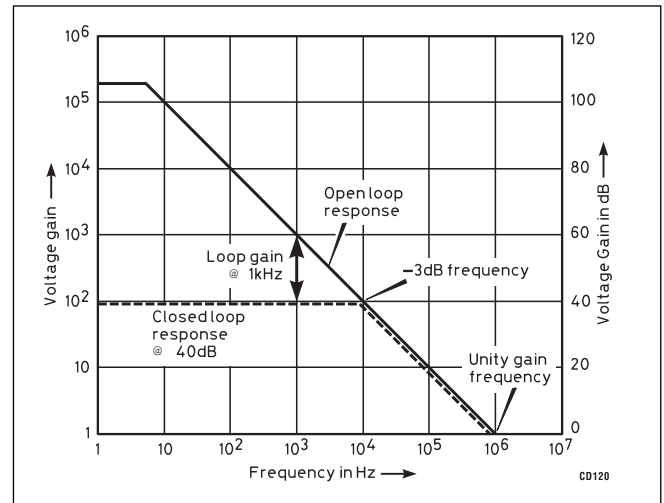

Fig 5.41: Open-loop, closed-loop and loop gain of an op-amp, internally compensated for 6dB/octave roll-off

amps is kept, by internal frequency compensation, to 90° , which coincides with a gain roll-off of $6\text{dB}/\text{octave}$ or $20\text{dB}/\text{decade}$. In **Fig 5.41**, note that the open-loop voltage gain from zero up to 6Hz is $200,000$ or 10^6dB . From 6Hz , the long slope is at $-6\text{dB}/\text{octave}$ until it crosses the unity gain (0dB) line at 1MHz . At any point along that line the product of gain and frequency is the same: 10^6 . If one now applies external feedback to achieve a signal voltage or closed-loop gain of, say, 100 times, the -3dB point of the resulting audio amplifier would be at $10^6/100 = 10\text{kHz}$ and from one decade further down, ie 1kHz to DC, the closed-loop gain would be flat within 1% . At 3kHz , ie the top of the communication-quality audio range, this amplifier would be only 1dB down and this would just make a satisfactory 40dB voice amplifier. If one wished to make a 60dB amplifier for the same frequency range, an op-amp with a gain-bandwidth product of at least $10^7 = 10\text{MHz}$ should be used or one without internal frequency compensation.

Op-amp types

The specifications given above apply to the general-purpose bipolar op-amp $\mu\text{A}741\text{C}$. There are special-purpose op-amps for a variety of applications, only a few are mentioned here.

Fast op-amps: The OP-37GP has high unity gain bandwidth (63MHz), high slew rate ($13.5\text{V}/\mu\text{s}$) and low noise, ($3\text{nV}/\sqrt{\text{Hz}}$) which is important for low-level audio. The AD797 has a gain bandwidth product of 110MHz . It has a slew rate of $20\text{V}/\mu\text{s}$ and has an extremely low noise. The input noise voltage is $0.9\text{nV}/\sqrt{\text{Hz}}$. This device is fairly expensive but has sufficient bandwidth that it can be used as an IF amplifier at 455kHz . The low input noise voltage means that it will give a good signal/noise when driven from a low impedance source (eg 50ohms).

The AD797 also has very good DC characteristics. The input offset voltage is typically $25\mu\text{V}$. If this device is used, the manufacturers data sheet should be consulted [19]. This shows how the op-amp should be connected and decoupled to ensure stability.

FET-input op-amps: The TL071-C has the very low input current characteristic of FET gates ($I_{os} \leq 5\text{pA}$) necessary if very-high feedback resistances (up to $10\text{M}\Omega$) must be used, but it will work on a single battery of 4.5V , eg in a low-level microphone amplifier, for which it has the necessary low noise. The input impedance is in the teraohm ($10^{12}\Omega$) range.

Power op-amps: The LM383 is intended for audio operation with a closed-loop gain of 40dB and can deliver up to 7W to a 4Ω speaker on a single 20V supply, 4W on a car battery, and can dissipate up to 15W if mounted on an adequate heatsink.

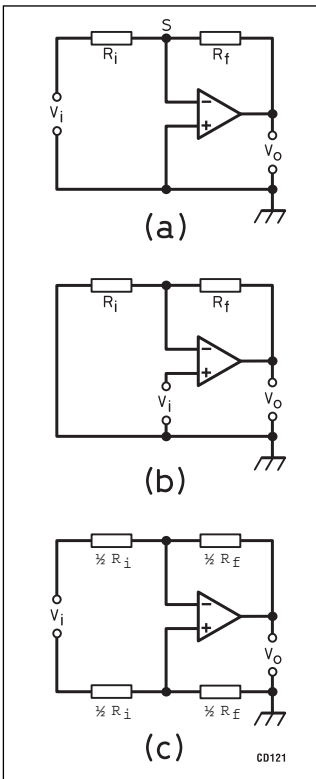

Fig 5.42: Three basic op-amp circuits: (a) inverting; (b) non-inverting; and (c) differential amplifiers

Basic op-amp circuits

Fig 5.42 shows three basic configurations: inverting amplifier (a), non-inverting amplifier (b) and differential amplifier (c).

The operation of these amplifiers is best explained in terms of the ideal op-amp defined above. In (a), if \$V_o\$ is finite and the op-amp gain is infinite, the voltage between the (-) and (+) input terminals must approach zero, regardless of what \$V_i\$ is; with the (+) input earthed, the (-) input is also at earth potential, which is called virtual earth. The signal current \$I_s\$ driven by the input voltage \$V_i\$ through the input

resistor \$R_i\$ will, according to Ohm's Law, be \$V_i/R_i\$. The current into the ideal op-amp's input being zero, the signal current has nowhere to go but through the feedback resistor \$R_f\$ to the output, where the output voltage \$V_o\$ must be \$-I_s R_f\$; hence:

$$V_o = -V_i \frac{R_f}{R_i} \text{ in which } -\frac{R_f}{R_i} = A_{cl}, \text{ the closed-loop gain}$$

The signal source 'sees' a load of \$R_i\$; it should be chosen to suitably terminate that signal source, consistent with a feedback resistor which should, for general purpose bipolar op-amps, be between 10kΩ and 100kΩ; with FET-input op-amps, feedback resistors up to several megohms can be used.

The junction marked 'S' is called the summing point; several input resistors from different signal sources can be connected to the summing point and each would independently send its signal current into the feedback resistor, across which the algebraic sum of all signal currents would produce an output voltage. A summing amplifier is known in the hi-fi world as a mixing amplifier; in amateur radio, it is used to add, not mix, the output of two audio oscillators together for two-tone testing of SSB transmitters.

For the non-inverting amplifiers, Fig 5.42(b), the output voltage and closed-loop gain derivations are similar, with the (-) input assuming \$V_i\$:

$$V_o = V_i \frac{R_i + R_f}{R_i} \text{ in which } \frac{R_i + R_f}{R_i} = A_{cl}, \text{ the closed loop gain}$$

The signal source 'sees' the very high input impedance of the bare op-amp input. In the extreme case where \$R_i = \infty\$, ie left out, and \$R_f = 0\$, \$V_o = V_i\$ and the circuit is a unity-gain voltage follower, which is frequently used as an impedance transformer having an extremely high input impedance and a near-zero output impedance. Non-inverting amplifiers cannot be used as summing amplifiers.

A differential amplifier is shown in Fig 5.42(c). The differential input, ie \$V_i\$, is amplified according to the formulas given above for the inverting amplifier. The common-mode input, ie the average of the input voltages measured against earth, is rejected to the extent that the ratio of the resistors connected to the (+) input equals the ratio of the resistors connected to the (-) input. A differential amplifier is useful in 'bringing to earth' and amplifying the voltage across a current sampling resistor of which neither end is at earth potential; this is a common requirement in current-regulated power supplies; see also Fig 5.33.

Power supplies for op-amps

Where the DC output voltage of an op-amp is significant and required to assume earth potential for some inputs, dual power supplies are required. Where a negative voltage cannot be easily obtained from an existing mains supply, eg in mobile equipment, a voltage mirror can be used. It is an IC which converts a positive supply voltage into an almost equal negative voltage, eg type Si7661CJ. Though characterised when supplied with \$\pm 15V\$, most op-amps will work off a wide range of supply voltages, typically \$\pm 5V\$ to \$\pm 18V\$ dual supplies or a single supply of 10V to 36V, including 13.8V. One must be aware, however, that the output of most types cannot swing closer to either supply bus than 1-3V.

In audio applications, circuits can be adapted to work off a single supply bus. In Fig 5.43, the AC-and-DC form of a typical inverting amplifier with dual power supplies (a) is compared with the AC-only form (b) shown operating off a single power supply.

The DC input voltage and current errors are only of the order of millivolts but if an amplifier is programmed for high gain, these errors are amplified as much as the signal and spoil the accuracy of the output.

In Fig 5.43(a), two measures reduce DC errors. The input error created by the bias current into the (-) input is compensated for by the bias current into the (+) input flowing through \$R_b\$, which is made equal to the parallel combination of \$R_i\$ and \$R_f\$. The remaining input error, \$I_{os} \cdot R_b + V_{os}\$, is trimmed to zero with \$RV_{os}\$, which is connected to a pair of amplifier pins intended for that purpose. Adjustment of \$RV_{os}\$ for \$V_o = 0\$ must be done with the \$V_i\$ terminals shorted.

Note that some other amplifier designs use different offset arrangements such as connecting the slider of the offset potentiometer to \$+V_s\$. Consult the data sheet or catalogue.

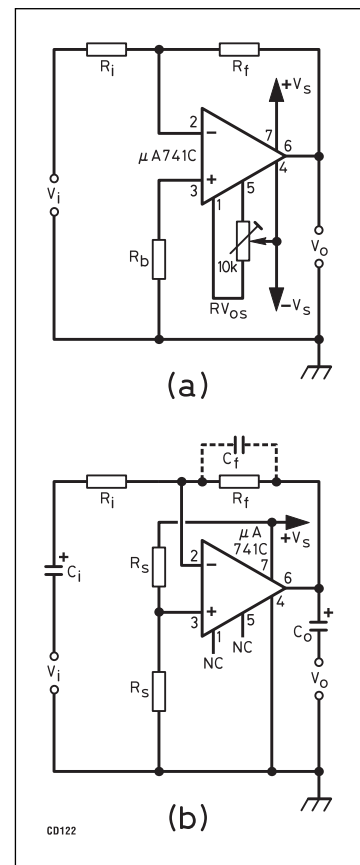

Fig 5.43: DC to audio amplifier (a) requires dual power supplies; it has input bias current and voltage offset compensation. The audio-only amplifier (b) needs only a single power supply

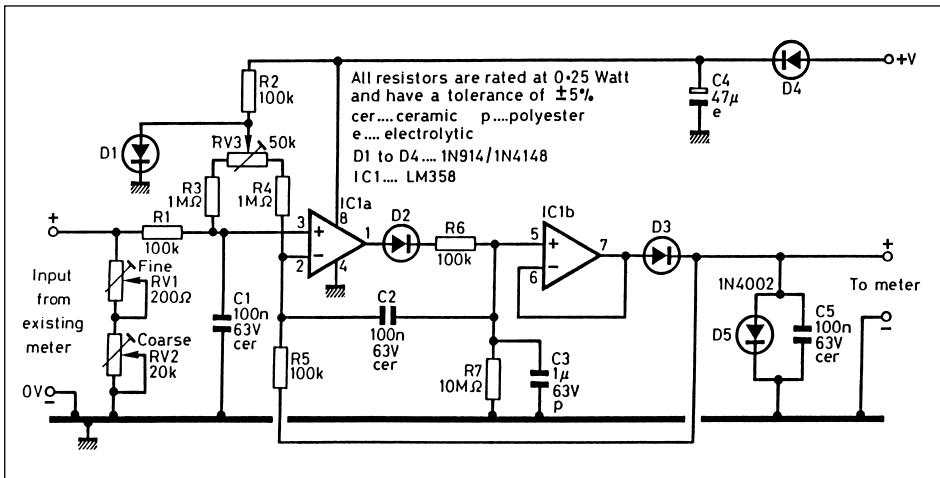

Fig 5.44: A PEP-reading module for RF power meters using a dual op-amp (GW4NAH)

In audio-only applications, DC op-amp offsets are meaningless as input and output are blocked by capacitors C_i and C_o in Fig 5.43(b). Here, however, provisions must be made to keep the DC level of the inputs and output about half-way between the single supply voltage and earth. This is accomplished by connecting the (+) input to a voltage divider consisting of the two resistors R_5 . Note that the DC closed loop gain is unity as C_i blocks R_i .

In the audio amplifier of Fig 5.43(b), the high and low frequency responses can be rolled off very easily. To cut low-frequency response below, say 300Hz, C_i is dimensioned so that

at 300Hz, $X_{C_i} = R_i$. To cut high-frequency response above, say 3000Hz, a capacitor C_f is placed across R_f ; its size is such that at 3000Hz, $X_{C_f} = R_f$.

For more sophisticated frequency shaping, see the section on active filters.

A PEP-reading module for RF power meters

The inertia of moving-coil meters is such that they cannot follow speech at a syllabic rate and even if they could, the human eye would be too slow to follow. The usual SWR/power meter found in most amateur stations, calibrated on CW, is a poor PEP indicator.

GW4NAH designed an inexpensive circuit [20], Fig 5.44, on a PCB small enough to fit into the power meter, which will rise to a peak and hold it there long enough for the meter movement, and the operator, to follow.

The resistance of RV1 + RV2 takes the place of the meter movement in an existing power meter; the voltage across it is fed via R1 and C1 to the (+) input of op-amp IC1a. Its output charges C3 via D2 and R6 with a rise time of 0.1s, but C3 can discharge only through R7 with a decay time constant of 10s. The voltage on C3 is buffered by the unity-gain voltage follower IC1b and is fed via D3 to the output terminals to which the original meter movement is now connected.

The input-to-output gain of the circuit is exactly unity by virtue of $R_5/R_1 = 1$. C2 creates a small phase advance in the feedback loop to prevent overshoot on rapid transients. The LM358 dual op-amp was chosen because, unlike most, it will work down to zero DC output on a single supply.

The small voltage across D1 is used to balance out voltage and current offsets in the op-amps, for which this IC has no built-in provisions, via R3, R4 and RV3. D4 protects against supply reversals and C4 is the power supply bypass capacitor. D5 and C5 protect the meter movement from overload and RF respectively.

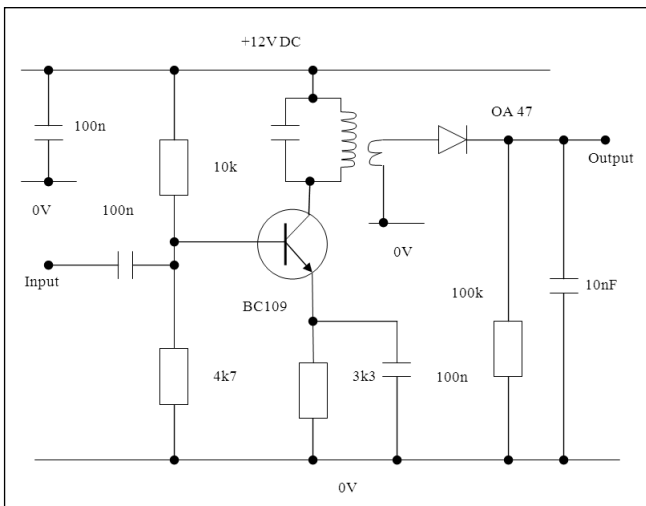

Fig 5.45: Transistor IF amplifier with diode detector

AM Detectors

The advantage of AM (double sideband / full carrier) is that transmitters and receivers are generally much less complicated than for SSB. For the beginner it is relatively easy to build AM equipment. The detector stage of an AM receiver may consist of a single diode operating as a rectifier. Fig 5.45 shows an example.

This detector has a voltage below which it will not detect. This is because of the threshold voltage of the diode. It is desirable to have a low threshold voltage and this can be achieved by using a germanium diode. It should be noted, however, that not all germanium diodes have the same threshold voltage and it is beneficial to select a diode which has a low voltage. A good choice is the OA47, and if more than one is available, it may be useful to select the one with the lowest threshold voltage because there is always a small variation between diodes of the same type. This is easily done by using a modern multimeter, most of which will show the forward voltage of a diode. Typical voltage for an OA47 type diode is approximately 240mV.

If a lower threshold than this is required, then an active rectifier can be used. An example of this is shown in Fig 5.46. This circuit uses a diode in a feedback circuit. This uses an op amp to reduce the threshold of the detector, and gives a value of typically 25mV.

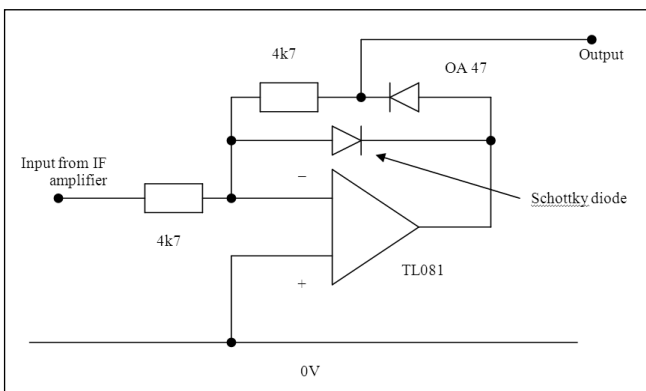

Fig 5.46: Active rectifier detector

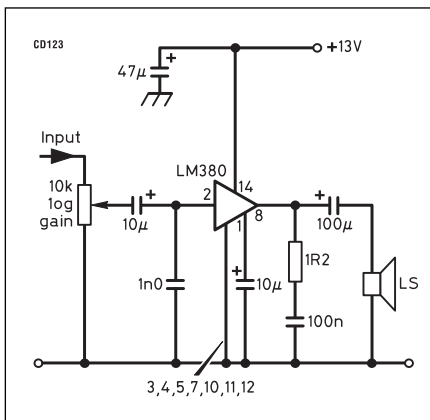

Fig 5.47: This simple receiver audio IC provides up to 40dB voltage gain and over a watt of low-distortion output power to drive an 8-ohm loud-speaker

Receiver Audio

The audio signal obtained from the demodulator of a radio receiver generally requires filtering and voltage amplification; if a loudspeaker is to be the 'output transducer' (as distinct from headphones or an analogue-to-digital converter for computer processing) some power amplification is also required. For audio filtering, see the section on filters. For voltage amplification, the op-amp is the active component of choice for reasons explained in the section on them.

There is also a great variety of ICs which contain not only the op-amp but also its gain-setting resistors and other receiver functions such as demodulator, AGC generator and a power stage dimensioned to drive a loudspeaker. A fraction of a watt is sufficient for a speaker in a quiet shack but for mobile operation in a noisy vehicle several watts are useful. Design, then, comes down to the selection from a catalogue or the junk box of the right IC, ie one that offers the desired output from the available input signal at an affordable price and on available power supply voltages.

The data sheet of the IC selected will provide the necessary details of external components and layout. Fig 5.47 is an example of voltage and power amplification in an inexpensive 14-pin DIL IC; the popular LM380 provides more than 1W into an 8Ω speaker on a single 13.8V supply. Even the gain-setting resistors are built-in.

Note that many ICs which were popular as audio amplifiers are now being withdrawn by the manufacturers. The newer devices which replace them are often switched-mode amplifiers. These offer advantages for the user because they are more efficient than linear amplifiers and hence require less heatsinking. They are not recommended however, for use in a receiver because of the significant amount of radio-frequency energy generated by the amplifier.

If a receiver is used for long periods, it can become fatiguing for the operator to listen to receiver audio. This effect can be reduced by the use of good quality components in the receiver audio stages (particularly resistors and capacitors), thus improving the receiver audio and reducing fatigue. One solution is to use a good quality loudspeaker, and many hi-fi loudspeakers designed as mid-range speakers provide a bandwidth which is optimum for communications (300 - 3000Hz). The optimum enclosure for a mid-range speaker is typically 1litre, which is quite small.

Transmitter Audio

The audio processing in amateur as in commercial and military transmitters consists of low-level voltage amplification, compression, limiting and filtering, all tasks for op-amp circuitry as described in the section on them. The increase in the consumer usage of radio transmitters in cellular telephones and private mobile radios has given incentive to IC manufacturers to integrate ever more of the required circuitry onto one chip.

First, an explanation of a few terms used in audio processing: clipper, compressor, VOGAD and expander.

The readability of speech largely resides in the faithful reproduction of consonant sounds; the vowels add little to the readability but much to the volume. Turning up the microphone gain does enhance the consonant sounds and thereby the readability, but the vowel sounds would then overload the transmitter, distort the audio and cause RF splatter. One remedy is to linearly amplify speech up to the amplitude limit which the transmitter can process without undue distortion and remove amplitude peaks exceeding that limit. This is called clipping.

If a waveform is distorted, however, harmonics are created and as harmonics of the lower voice frequencies fall within the 300-2700Hz speech range where they cannot subsequently be filtered out, too much clipping causes audible distortion and reduces rather than enhances readability. One way to avoid this, at least in a single-sideband transmitter, is to do the clipping at a higher frequency, eg the IF where the SSB signal is generated; the harmonics then fall far outside the passband required for speech and can be readily filtered out.

VOGAD stands for 'voice-operated gain adjustment device'. It automatically adjusts the gain of the microphone amplifier so that the speech level into the transmitter, averaged over several syllables, is almost independent of the voice level into the microphone. It is widely used, eg in hand-held FM transceivers.

A compressor is an amplifier of which the output is proportional to the logarithm of the input. Its purpose is to reduce the dynamic range of the modulation, in speech terms the difference between shouting and whispering into the microphone,

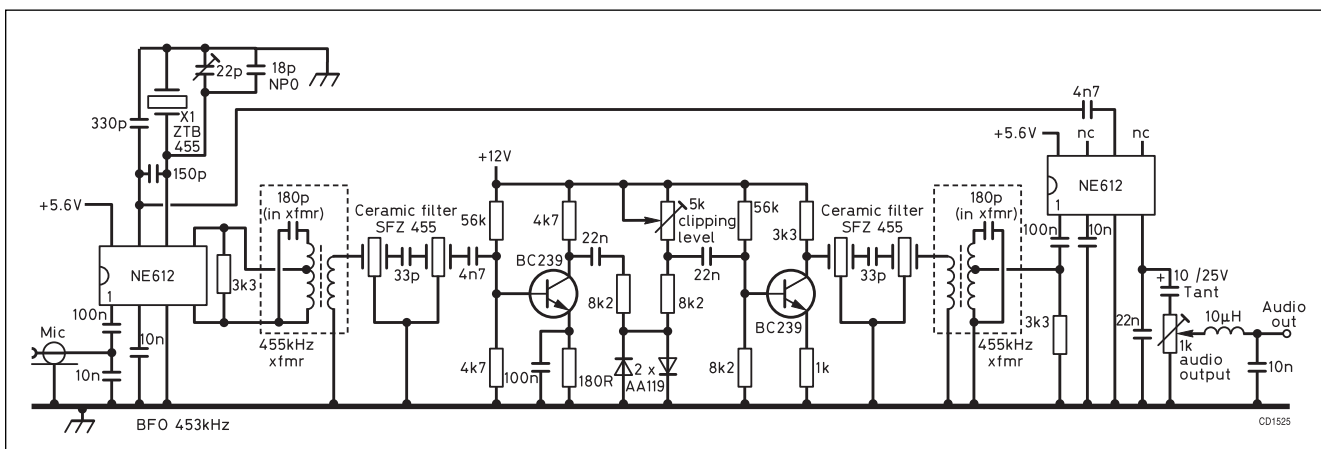

Fig 5.48: The DF4ZS RF speech clipper combines high compression with low distortion

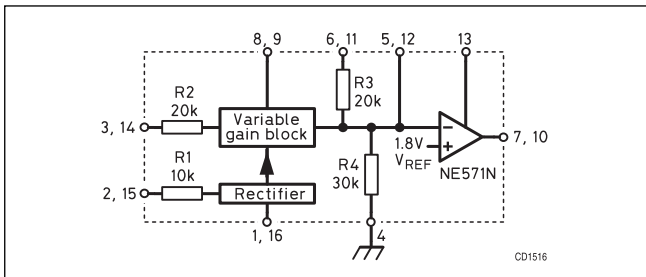

Fig 5.49: Block diagram of the Philips NE571N two-channel compressor. Basic input-to-output characteristics are as follows:

Compressor input level or expander output level (dBm)	Compressor output level or expander input level (dBm)
+20	+10
0	0
-20	-10
-40	-20
-60	-30
-80	-40

and thereby improve the signal to noise ratio at the receiving end. If best fidelity is desired, the original contrast can be restored in the receiver by means of an expander, ie an exponential amplifier; this is desirable for hi-fi music but for speech it is seldom necessary.

A compander is a compressor and an expander in one unit, nowadays one IC. It could be used in a transceiver, with the compressor in the transmit and the expander in the receive chain.

An RF speech clipper

As explained above, clipping is better done at a radio frequency than at audio. Analogue speech processors in the better pre-DSP SSB transceivers clip at the intermediate frequency at which the SSB signal is generated.

Rigs without a speech processor will benefit from the stand-alone unit designed by DF4ZS [21]. In Fig 5.48 the left NE612 IC (a cheaper version of the NE602 described above) mixes the microphone audio with a built-in 453kHz BFO to yield 453kHz + audio, a range of 453.3 to 455.7kHz. The following filter removes all other mixing products. The signal is then amplified, clipped by the back-to-back diodes, amplified again, passed through another filter to remove the harmonics generated by the clipping process, and reconverted to audio in the right-hand NE612. A simple LC output filter removes non-audio mixing products.

A compander IC

The Philips NE571N Compaander IC contains two identical channels, each of which can be externally connected as a compressor or as an expander. Referring to Fig 5.49, this can be explained (in a very simplified way) as follows:

To expand, the input signal to the device is also fed into the rectifier which controls a 'variable gain block' (VGB); if the input is high, the current gain of the VGB is also high. For example, if the input goes up 6dB, the VGB gain increases by 6dB as well and the current into the summing point of the op-amp, and hence the output, go up 12dB, R3 being used as the fixed feedback resistor.

To compress, the output is fed into the rectifier and the VGB is connected in the feedback path of

the op-amp with R3 being connected as the fixed input resistor. Now, if both the output and the VGB gain are to go up 6dB, the input must rise 12dB.

Having two channels enables application as a stereo compressor or expander, or, in a transceiver, one channel can compress the transmitted audio while the other expands the receiver output.

A voice record-playback device

Contesters used to get sore throats from endlessly repeated 'CQs'. Repeated voice messages can now be sent with an IC which can record into non-volatile erasable analogue memory a message of 10-20 seconds in length from a microphone, and play it back with excellent fidelity through a loudspeaker or into the microphone socket of a transmitter. Playback can be repeated as often as desired and then instantly cleared, ready for a new message. The US company Information Storage Devices' ISD1100-series ICs sample incoming audio at a 6.4kHz rate, which permits an audio bandwidth up to 2.7kHz. Fig 5.50 shows a simple application diagram.

Velleman, a Belgian manufacturer, makes a kit, including a PCB, on which to assemble the IC and the required passive components and switches. ON5DI showed how to interface this assembly with a transceiver and its microphone [22].

FILTERS AND LC COUPLERS

Filters are circuits designed to pass signals of some frequencies and to reject or stop signals of others. Amateurs use filters ranging in operation from audio to microwaves. Applications include:

- Preselector filters which keep strong out-of-band signals from overloading a receiver.
- IF (intermediate frequency) filters which provide adjacent-channel selectivity in superheterodyne receivers.
- Audio filters which remove bass and treble, which are not essential for speech communication, from a microphone's output. This minimises the bandwidth taken up by a transmitted signal.
- A transmitter output is filtered, using a low-pass filter, to prevent harmonics being radiated.
- Mains filters, which are low-pass filters, used to prevent mains-borne noise from entering equipment.

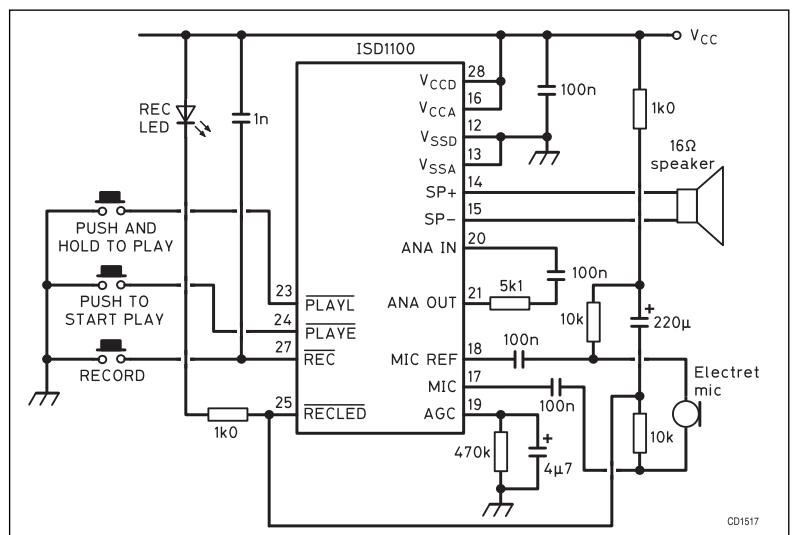

Fig 5.50: A record-playback IC, with its associated circuitry, will record 10-20 sec of speech, store it in non-volatile memory, and play it back at the push of a button

Filters are classified by their main frequency characteristics. High-pass filters pass frequencies above their cut-off frequency and stop signals below that frequency. In low-pass filters the reverse happens. Band-pass filters pass the frequencies between two cut-off frequencies and stop those below the lower and above the upper cut-off frequency. Band-reject (or band-stop) filters stop between two cut-off frequencies and pass all others. Peak filters and notch filters are extremely sharp band-pass and band-reject filters respectively which provide the frequency characteristics that their names imply.

A coupler is a unit that matches a signal source to a load having an impedance which is not optimum for that source. An example is the matching of a transmitter's transistor power amplifier requiring a 2-ohm load to a 50-ohm antenna. Frequently, impedance matching and filtering is required at the same spot, as it is in this example, where harmonics must be removed from the output before they reach the antenna. There is a choice then, either to do the matching in one unit, eg a wide-band transformer with a $1:\sqrt{50/2} = 1:5$ turns ratio and the filtering in another, ie a 'standard' filter with 50Ω input and output, or to design a special filter-type LC circuit with a 2Ω input and 50Ω output impedance. In multiband HF transceivers, transformers good for all bands and separate 50Ω/50Ω filters for each band would be most practical. For UHF, however, and for the high impedances in RF valve anode circuitry, there are no satisfactory wide-band transformers; the use of LC circuits is required.

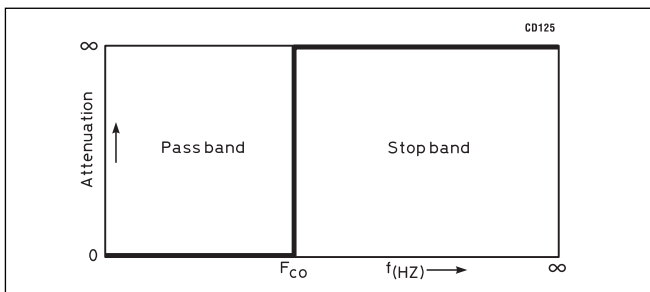

Fig 5.51: Attenuation versus frequency plot of an ideal low-pass filter. No attenuation (insertion loss) in the pass-band, infinite attenuation in the stop-band, and a sharp transition at the cut-off frequency

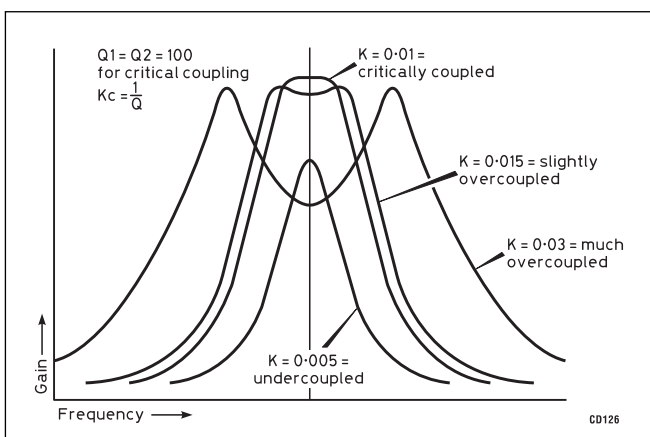

Fig 5.52: Frequency response of a filter consisting of two resonant circuits tuned to the same frequency as a function of the coupling between them (after Terman). Under-coupling provides one sharp peak, critical coupling gives a flat top, mild overcoupling widens the top with an acceptably small dip and gross overcoupling results in peaks on two widely spaced frequencies. All these degrees of coupling have their applications

Ideal Filters and the Properties of Real Ones

Ideal filters would let all signals in their intended pass-band through unimpeded, ie have zero insertion loss, suppress completely all frequencies in their stop-band, ie provide infinite attenuation, and have sharp transitions from one to the other at their cut-off frequencies (**Fig 5.51**). Unfortunately such filters do not exist. In practice, the cut-off frequency, that is the transition point between pass-band and stop-band, is generally defined as the frequency where the response is -3dB (down to 70.7% in voltage) with respect to the response in the pass-band; in very sharp filters, such as crystal filters, the -6dB (half-voltage) points are frequently considered the cut-off frequencies. There are several practical approximations of ideal filters but each of these optimises one characteristic at the expense of others.

LC Filters

If two resonant circuits are coupled together, a band-pass filter can be made. The degree of coupling between the two resonant circuits, both of which are tuned to the centre frequency, determines the shape of the filter curve (**Fig 5.52**). Undercoupled, critically coupled and overcoupled two-resonator filters all have their applications.

Four methods of achieving the coupling are shown in **Fig 5.53**. The result is always the same and the choice is mainly one of convenience. If the signal source and load are not close together, eg on different PCBs, placing one resonant circuit with each and using link coupling is recommended to avoid earth loops. If the resonant circuits are close together, capacitive coupling between the 'hot ends' of the coils is easy to use and the coupling can be adjusted with a trimmer capacitor. Stray inductive coupling between adjacent capacitively coupled resonant circuits is avoided by placing them on opposite sides of a shield and/or placing the axes of the coils (if not on toroids or pot cores) at right-angles to one-another. The formulae for the required coupling are developed in the General Data chapter.

All filters must be properly terminated to give predictable bandwidth and attenuation. **Table 5.10** gives coil and capacitor values for five filters, each of which passes one HF band. (The 7 and 14MHz filters are wider than those bands to permit their use in frequency multiplier chains to the FM part of the 29MHz band.) Included in each filter input and output is a 15kΩ termination resistor, as is appropriate for filters between a very high-impedance source and a similar load, eg the anode of a pentode valve and the grid of the next stage, or the drain of one dual-gate MOSFET amplifier and the gate of the next.

Frequently, a source or load has itself an impedance much lower than 15kΩ, eg a 50Ω antenna. These 50Ω then become the termination and must be transformed to 'look like' 15kΩ by tapping down on the coil. As the circulating current in high-Q resonant circuits is many times larger than the source or load current and if the magnetic flux in a coil is the same in all its turns, true in coils wound on powdered iron or ferrite toroids or pot cores, the auto-transformer formula may be used to determine where the antenna tap should be: at $\sqrt{50/15,000} \approx 6\%$ up from the earthy end of the coil. In coils without such cores, the flux in the end turns is less than in the centre ones, so the tap must be experimentally located higher up the coil. Impedances lower than 50Ω can be accommodated by placing that source or load in series with the resonant circuit rather than across all or part of it.

DC operating voltages to source and load devices are often fed through the filter coils. If properly bypassed, this does not affect filter operation. To avoid confusion, DC connections and bypass capacitors are not shown in the filter circuitry in this chapter.

Several more sophisticated LC filter designs are frequently used. All can be configured in high-pass, low-pass, band-pass and band-reject form. Butterworth filters have the flattest response in the pass-band. Chebyshev filters have a steeper roll-off to the stop-band but exhibit ripples in the pass-band, their

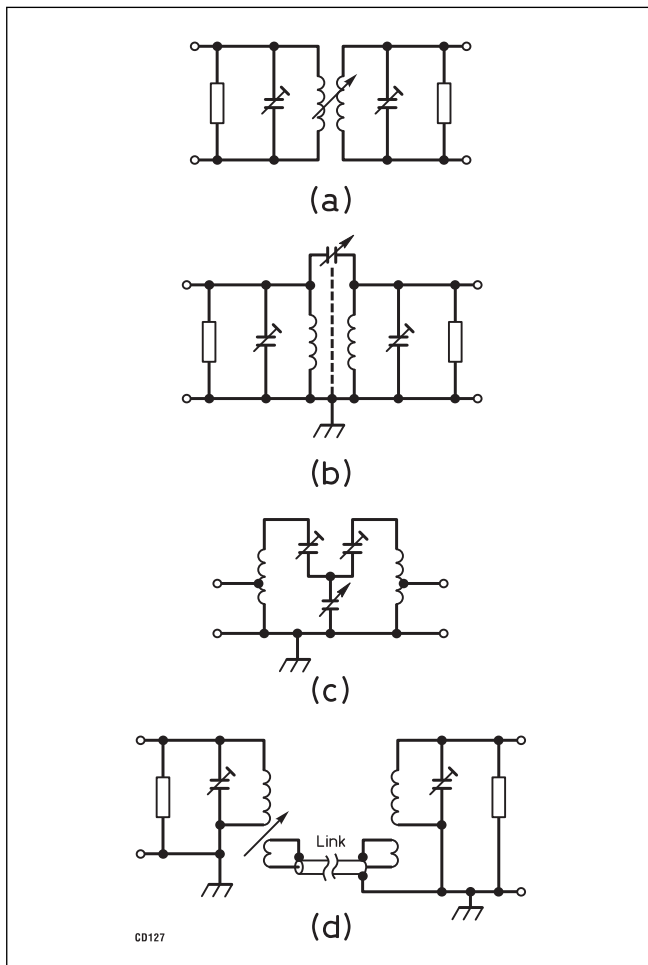

Fig 5.53: Four ways of arranging the coupling between two resonant circuits. Arrows mark the coupling adjustment. (a) Direct inductive coupling; the coils are side-by-side or end-to-end and coupling is adjusted by varying the distance between them. (b) 'Top' capacitor coupling; if the coils are not wound on toroids or pot cores they should be shielded from each other or installed at right-angles to avoid uncontrolled inductive coupling. (c) Common capacitor coupling; if the source and/or load have an impedance lower than the proper termination, they can be 'tapped down' on the coil (regardless of coupling method). (d) Link coupling is employed when the two resonant circuits are physically separated

number depending on the number of filter sections. Elliptic filters have an even steeper roll-off, but have ripples in the stop-band (zeroes) as well as in the pass-band (poles): see **Fig 5.54**. Chebyshev and elliptical filters have too much overshoot, particularly near their cut-off frequencies, for use where pulse distortion must be kept down, eg in RTTY filters.

The calculation of component values for these three types would be a tedious task but for filter tables normalised for a cut-off frequency of 1Hz and termination resistance of 1Ω (or 1MHz and 50Ω where indicated). These can be easily scaled to the desired frequency and termination resistance. See the General Data chapter for more information.

M-derived and constant-k filters are older designs with less-well-defined characteristics but amateurs use them because component values are more easily calculated 'long-hand'. The diagrams and formulae to calculate component values are contained in the General Data chapter.

From audio frequency up to, say, 100MHz, filter inductors are mostly wound on powdered-iron pot cores or toroids of a material and size suitable for the frequency and power, and capacitors ranging from polystyrene types at audio, to mica and ceramic types at RF, with voltage and current ratings commensurate with the highest to be expected, even under fault conditions.

Fig 5.55 shows an audio filter to provide selectivity in a direct-conversion receiver. It is a three-section elliptic low-pass filter with a cut-off frequency of 3kHz, suitable for voice reception.

To make any odd capacitance values of, say, 1% accuracy, start with the next lower standard value (no great accuracy required), measure it precisely (ie to better than 1%), and add what is missing from the desired value in the form of one or more smaller

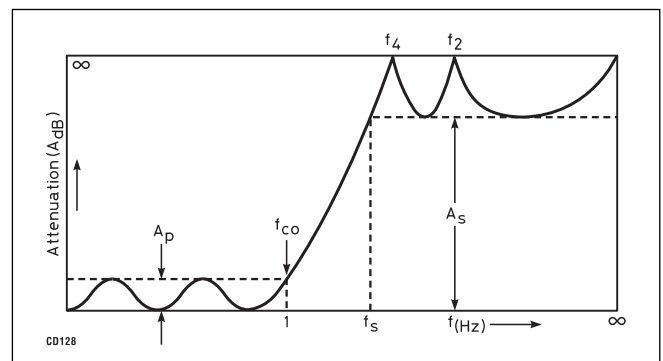

Fig 5.54: Attenuation vs frequency plot of a two-section elliptic low-pass filter. A is the attenuation (dB); A_p is the maximum attenuation in the pass-band or ripple; f_4 is the first attenuation peak; f_2 is the second attenuation peak with two-section filter; f_{co} is the frequency where the attenuation first exceeds that in the pass-band; A_s is the minimum attenuation in the stop-band; and f_s is the frequency where minimum stop-band attenuation is first reached

Lowest frequency (MHz)	Centre frequency (MHz)	Highest frequency (MHz)	Coupling (pF)	Parallel capacitance (pF)	L (μH)	Winding details (formers 3/4in long, 3/8in dia)
3.5	3.65	3.8	6	78	24	60t 32SWG close-wound
7	7.25	7.5	3	47	10	40t 28SWG close-wound
14	14.5	15	1.5	24	5	27t 24SWG close-wound
21	21.225	21.45	1	52	1	12t 20SWG spaced to 3/4in
28	29	30	0.6	10 primary 30 secondary	3 1	21t 24SWG spaced to 3/4in 12t 20SWG spaced to 3/4in

The use of tuning slugs in the coils is not recommended. Capacitors can be air, ceramic or mica compression trimmers. Adjust each coupler to cover frequency range shown.

Table 5.10: Band-pass filters for five HF bands and 15kΩ input and output terminations as shown in Fig 5.53(b)

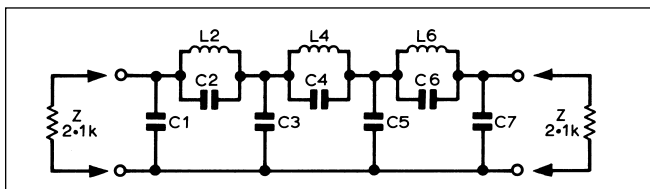

Fig 5.55: A three-section elliptic low-pass filter with 3kHz cut-off. C1 = 37.3nF, C2 = 3.87nF, C3 = 51.9nF, C4 = 19.1nF, C5 = 46.4nF, C6 = 13.5nF, C7 = 29.9nF, mica, polyester or polystyrene. L2 = 168mH, L4 = 125mH, L6 = 130mH are wound on ferrite pot cores
capacitors which are then connected in parallel with the first one. The smaller capacitors, having only a small fraction of the total value, need not be more accurate than, say, ±5%.

Filtering at VHF and Above

At HF and below, it may be assumed that filters will perform as designed if assembled from components which are known to have the required accuracy, either because they were bought to tight specifications or were selected or adjusted with precise test equipment. It was further assumed that capacitor leads had negligible self-inductance and that coils had negligible capacitance.

At VHF and above these assumptions do not hold true. Though filter theory remains the same, the mechanics are quite different. Even then, the results are less predictable and adjustment will be required after assembly to tune out the stray capacitances and inductances. A sweep-generator and oscilloscope provide the most practical adjustment method. A variable oscillator with frequency counter and a voltmeter with RF probe, plus a good deal of patience, can also do the job.

At VHF, self-supporting coils and mica, ceramic or air-dielectric trimmer capacitors give adequate results for most applications. For in-band duplex operation on one antenna, as is common in repeaters, bulky and expensive very-high-Q cavity resonators are required, however.

The band-pass filter of **Fig 5.56** includes four parallel resonant circuits [15]. Direct inductive coupling is used between the first two and the last two; capacitive coupling is used between the centre two, where a shield prevents stray coupling. The input and output connections are tapped down on their respective coils to transform the 50Ω source and load into the proper terminations. This filter can reduce harmonics and other out-of-band spurious emissions when transmitting and suppress strong out-of-band incoming signals which could overload the receiver.

At UHF and SHF, filters are constructed as stripline or coaxial transmission line sections with air-dielectric trimmer capacitors. One type of stripline, sometimes called microstrip, consists of carefully dimensioned copper tracks on one side of high-grade (glass-filled or PTFE, preferably the latter) printed circuit board 'above' a ground plane formed by the foil on the other side of that PCB. The principle is illustrated in **Fig 5.57** and calculations are given in the General Data chapter.

Many amateurs use PCB strip lines wherever very high Q is not mandatory, as they can be fabricated with the PCB-making skills and tools used for many other home-construction projects. Frequently, in fact, such filters are an integral part of the PCB on which the other components are assembled.

Fig 5.57; Basic microstrip half-wave resonator. The electrical length of the strips is made shorter than their nominal length so that trimmers at the voltage maxima can be used to tune to resonance; the mechanical length of the strips is shorter than the electrical length by the velocity factor arising from the dielectric constant of the PCB material

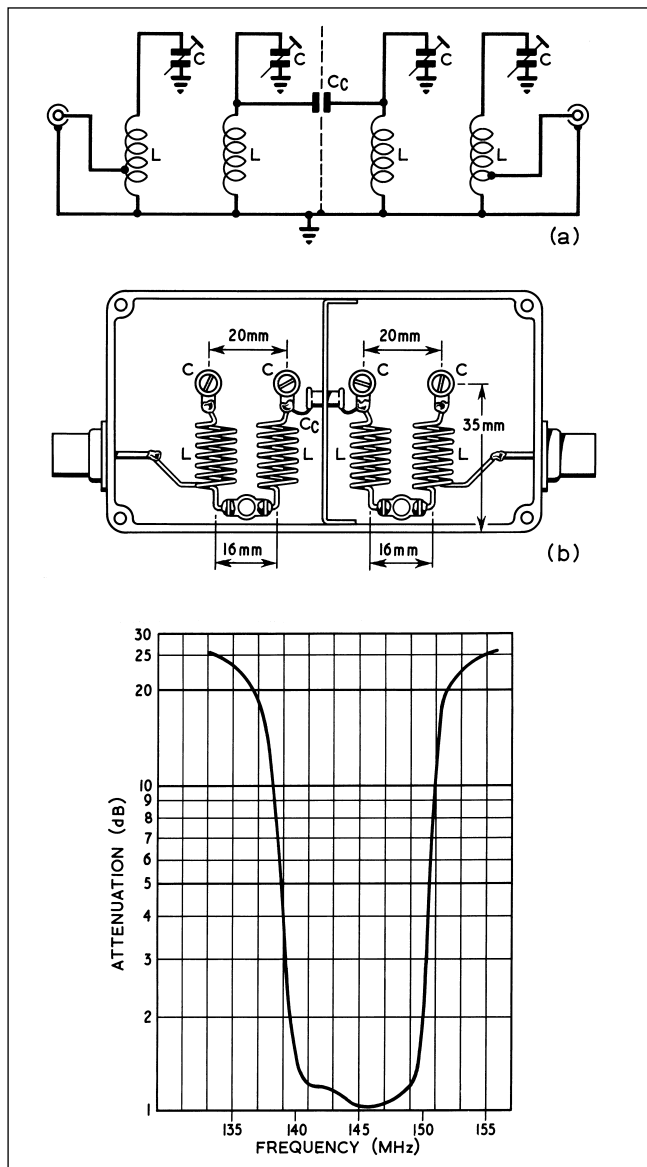
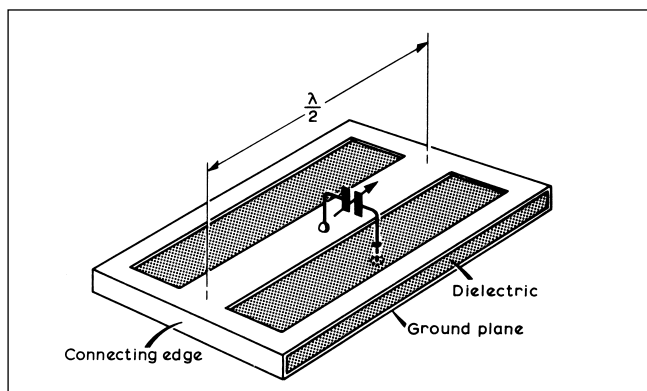

Fig 5.56: A four-section band-pass filter for 145MHz. (a) Direct inductive coupling between sections 1-2 and 3-4, top capacitor (0.5pF) coupling between sections 2-3; both input and output are tapped down on the coils for 50 ohm terminations. (b) The filter fits into an 11 x 6 x 3cm die-cast box; coils are 3/8in (9.5mm) inside dia, 6½ turns bare 18SWG (1.22mm dia) spaced 1 wire dia; taps 1t from earthy end; C are 1 - 6pF piston ceramic trimmers for receiving and QRP transmitting; for higher power there is room in the box for air trimmers. (c) Performance curve



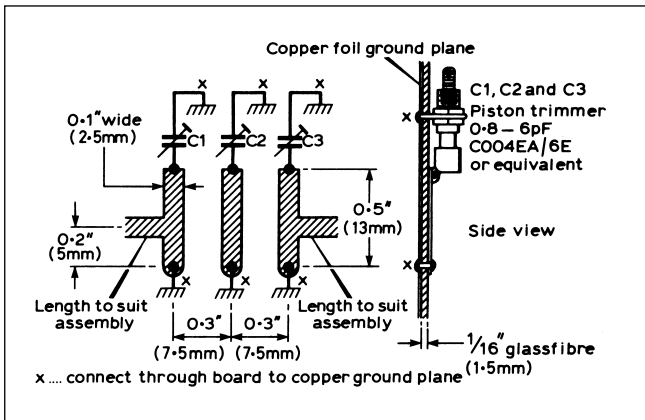

Fig 5.58: A 1.3GHz microstrip filter consisting of three quarter-wave resonators. Coupling is by the stray capacitance between trimmer stators. The input and output lines of 50 ohm microstrip are tapped down on the input and output resonators

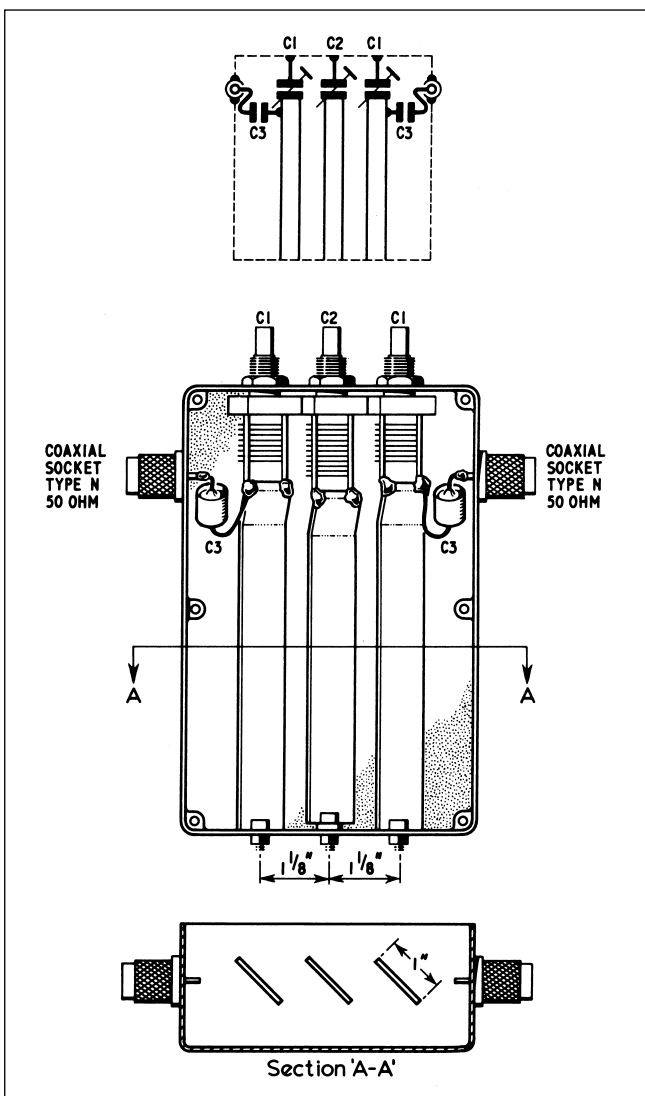

Fig 5.59: The circuit and layout for a 100W 145MHz slab-line filter. The strips are 1 x 1/16in (25 x 1.5mm) sheet copper, offset at 45° to avoid overcoupling. Input and output lines are 6 1/2in (165mm) long; the centre resonator is slightly shorter to allow for the greater length of C2 and a rib in the cast box. C1 = 50pF, C2 = 60pF, C3 = 4.4pF

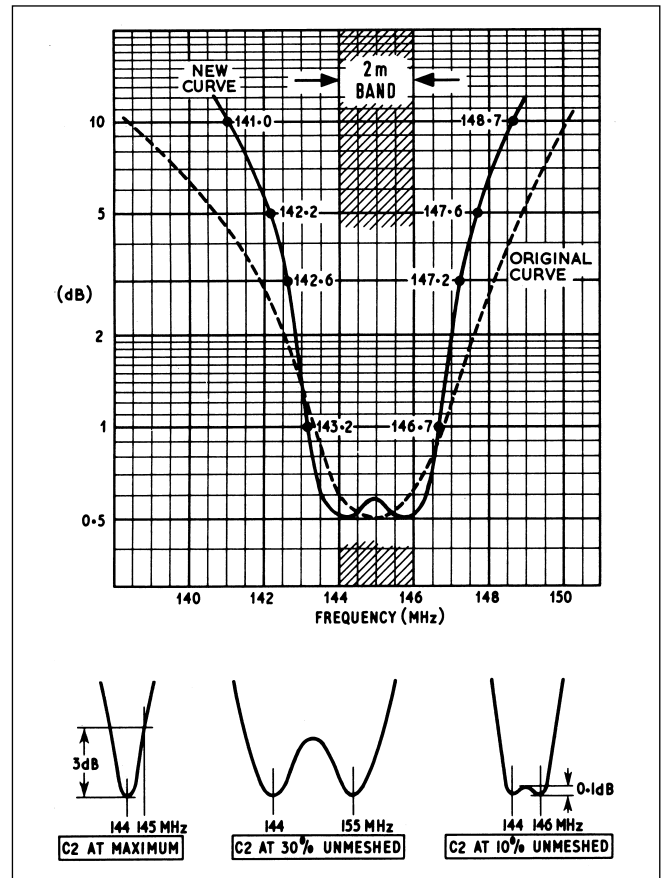

Fig 5.60: Performance curves of the 145MHz slab-line filter as affected by the setting of C2. Note that the insertion loss is only 0.6dB. Also, compare the 10dB bandwidth of this filter with that of the four-section LC filter: 7.7MHz for this filter when tuned to 'new curve', 13MHz for the four-section filter with small, lower-Q coils

Fig 5.58 exemplifies a PCB band-pass filter for the 1.3GHz band. It consists of three resonators, each of which is tuned by a piston-type trimmer. It is essential that these trimmers have a low-impedance connection to earth (the foil on the reverse side of the PCB). With 1.5pF trimmers, the tuning range is 1.1-1.5GHz. The insertion loss is claimed to be less than 1dB. The input and output lines, having a characteristic impedance of 50Ω, may be of any convenient length. This filter is not intended for high-power transmitters.

For higher power, the resonators can be sheet copper striplines, sometimes called slab lines, with air as the dielectric. **Fig 5.59** gives dimensions for band-pass filters for the 144MHz band [15]. The connections between the copper fingers and the die-cast box are at current maxima and must have the lowest possible RF resistance.

In the prototype, the ends of the strips were brazed into the widened screwdriver slots in cheesehead brass bolts. The 'hot' ends of the strips are soldered directly to the stator posts of the tuning capacitors. After the input and output resonators are tuned for maximum power throughput at the desired frequency with the centre capacitor fully meshed, the latter is then adjusted to get the desired coupling and thereby pass-band shape (**Fig 5.60**).

For the highest Q at UHF and SHF, and with it the minimum insertion loss and greatest out-of-band attenuation, coaxial resonators are used. Their construction requires specialised equipment and skills, as brass parts must be machined, brazed together and silver plated.

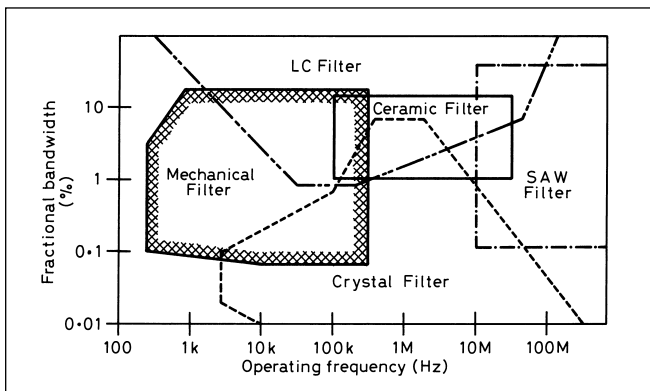

Fig 5.61: Typical frequency ranges for various filter techniques

LC Matching Circuits

LC circuits are used to match very low impedances, such as VHF transistor collectors, or very high impedances, such as valve anodes, to the 50 or 75-ohm coaxial cables which have become the standard for transporting RF energy between 'black boxes' and antennas. The desired match is valid only at or near the design frequency. The calculations for L, pi and L-pi circuits are given in the chapter on HF transmitters.

High-Q Filter Types

The shape factor of a band-pass filter is often defined as the ratio between its -60dB and -6dB bandwidth. In a professional receiver, a single-sideband filter with a shape factor of 1.8 could be expected, while 2.0 might be more typical in good amateur equipment. It is possible to make LC filters with such performance, but it would have to be at a very low intermediate frequency (10-20kHz), have many sections, and be prohibitively bulky, costly and complicated. The limited Q of practically realisable inductors, say 300 for the best, is the main reason. Hence the search for resonators of higher Q. Several types are used in amateur equipment, including mechanical, crystal, ceramic, and surface acoustic wave (SAW) filters. Each is effective in a limited frequency range and fractional bandwidth (the ratio of bandwidth to centre frequency in percent). See Fig 5.61.

Mechanical filters

There are very effective SSB, CW and RTTY filters for intermediate frequencies between 60 and 600kHz based on the mechanical resonances of small metal discs (Fig 5.62). The filter comprises three types of component: two magnetostrictive or piezoelectric transducers which convert the IF signals into mechanical vibrations and vice versa, a number of resonator discs, and coupling rods between those disks. Each disc represents the mechanical equivalent of a high-Q series resonant circuit, and the rods set the coupling between the resonators and thereby the bandwidth. Shape factors as low as 2 can be achieved. Mechanical filters were first used in amateur equipment by Collins Radio (USA). They still are offered as options in expensive amateur transceivers but with the advent of digital signal processing (DSP) in IF systems, typically between 10 and 20kHz, similar performance can be obtained at lower cost.

Crystal filters

Piezo-electric crystals, cut from man-made quartz bars, are resonators with extremely high Q, tens of thousands being common. Their electrical equivalent, Fig 5.63(a), shows a very large inductance L_s , an extremely small capacitance C_s and a small loss resistance R_s , in a series-resonant circuit. It is shunted by

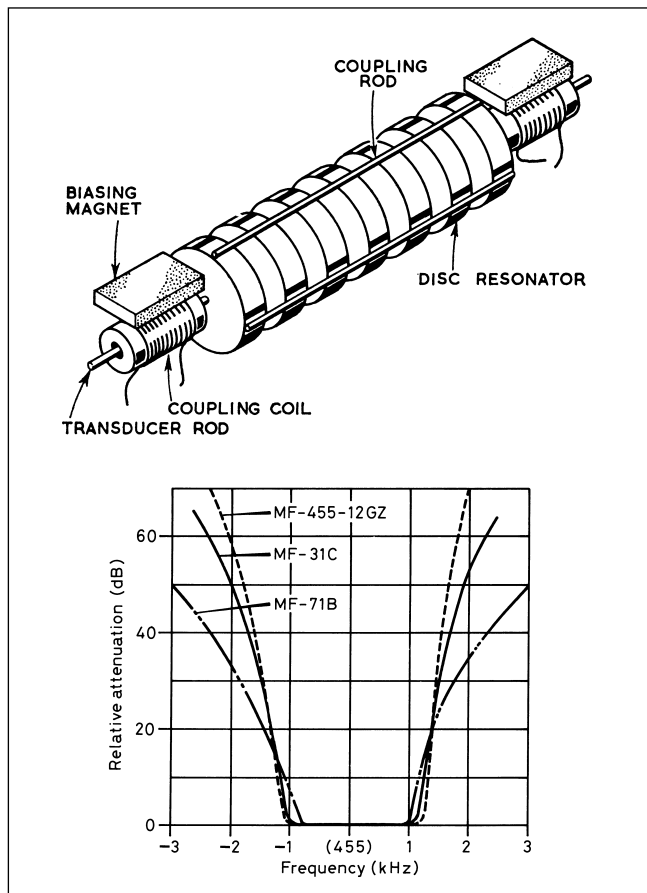

Fig 5.62: The Collins mechanical filter. An IF signal is converted into mechanical vibrations in a magnetostrictive transducer, is then passed, by coupling rods, along a series of mechanical resonators to the output transducer which reconverts into an electrical signal. Below are response curves of three grades of Goy miniatur mechanical filters

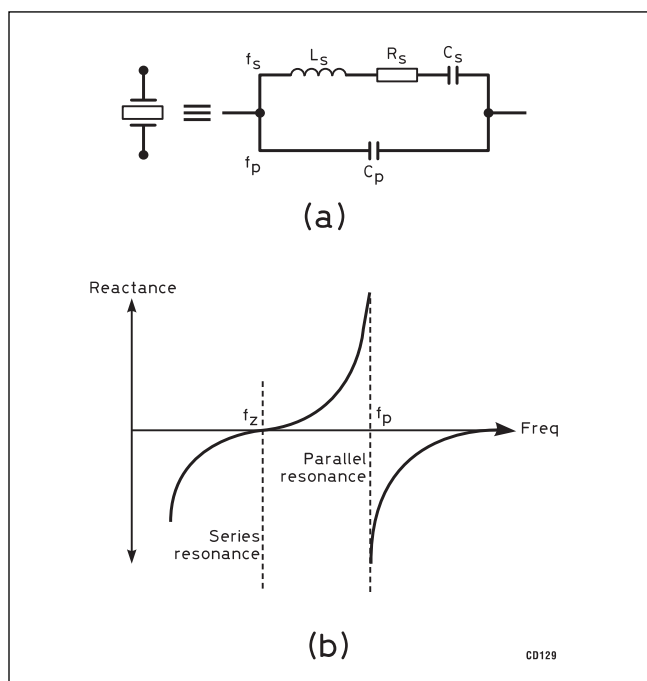

Fig 5.63: The crystal equivalent circuit (a), and its reactance vs frequency plot (b)

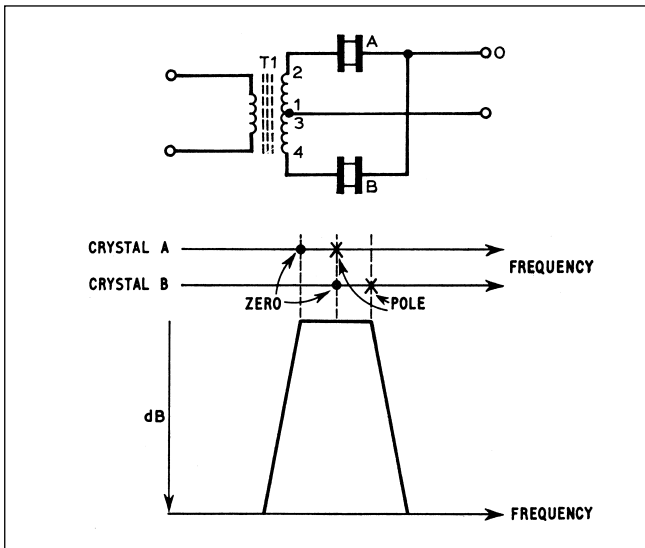

Fig 5.64: The basic single-section half-lattice filter diagram (top) and its idealised frequency plot (bottom). Note the poles and zeros of the two crystals in relation to the cut-off frequencies; if placed correctly, the frequency response is symmetrical. The bifilar transformer is required to provide balanced inputs

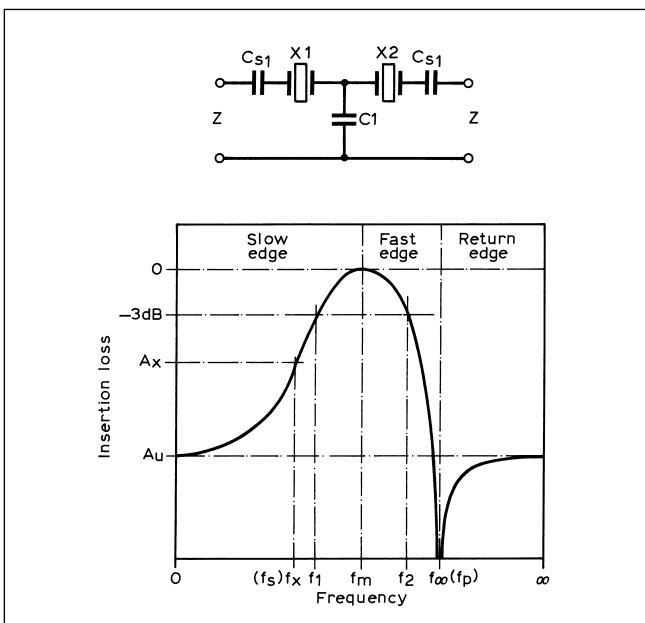

Fig 5.65: The basic two-pole ladder filter diagram (top) and its generalised frequency plot (bottom). Note that the crystals are identical but that the resulting frequency response is asymmetric

the parallel capacitance C_p , which is the real capacitance of the crystal electrodes, holder, socket, wiring and any external load capacitor one may wish to connect across the crystal.

At frequencies above the resonance of the series branch, the net impedance of that branch is inductive. This inductance is in parallel resonance with C_p at a frequency slightly above the series resonance: **Fig 5.63(b)**. The essentially mechanical series resonance, the zero, may be considered user-immovable but the parallel resonance or pole can be pulled down closer to the series resonant frequency by increasing the load capacitance, eg with a trimmer.

Though their equivalent circuit would suggest that crystals are linear devices, this is not strictly true. Crystal filters can therefore cause intermodulation, especially if driven hard, eg by a strong signal just outside the filter's pass-band. Sometimes, interchanging input and output solves the problem.

The two most common configurations are the half-lattice filter, **Fig 5.64**, and the ladder filter, **Fig 5.65**.

Half-lattice filter curves are symmetrical about the centre frequency, an advantage in receivers, but they require crystals differing in series resonant frequency by somewhat more than half the desired pass-band width and an RF transformer for each two filter sections. Two to four sections, four to eight crystals, are required in a good HF SSB receiver IF filter. Model XF-9B in **Table 5.11** is a high-performance filter which seems to be of this type. Half-lattice filters make good home construction projects only for the well-equipped and experienced.

Ladder filters require no transformers and use crystals of only one frequency but they have asymmetrical pass-band curves; this creates no problem in SSB generators but is less desirable in a receiver with upper and lower sideband selection. With only five crystals a good HF SSB generator filter can be made. Model XF-9A in **Table 5.11** seems to be of this type.

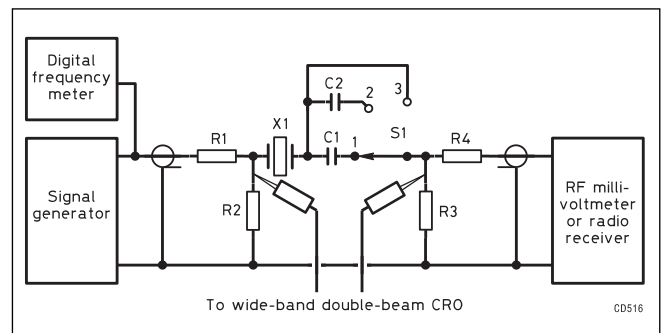

Fig 5.66: G3JIR's crystal test circuit. At resonance, both series (switch position 3) and parallel (switch positions 1 and 2), the two 'scope traces are in-phase. For 9MHz filter crystals, $R1 = R4 = 1k$, $R2 = R3 = 220$ ohms. The signal generator and frequency meter should have a frequency resolution of 10Hz

Filter type	XF-9A	XF-9B	XF-9C	XF-9D	XF-9E	XF-9M
Application	SSB TX	SSB TX/RX	AM	AM	NBFM	CW
Number of poles	5	8	8	8	8	4
6dB bandwidth (kHz)	2.5	2.4	3.75	5.0	12.0	0.5
Passband ripple (dB)	<1	<2	<2	<2	<2	<1
Insertion loss (dB)	<3	<3.5	<3.5	<3.5	<3	<5
Termination	500 /30pF	500 /30pF	500 /30pF	500 /30pF	1200 /30pF	500 /30pF
Shape factor	1.7 (6-50dB)	1.8 (6-60dB)	1.8 (6-60dB)	1.8 (6-60dB)	1.8 (6-60dB)	2.5 (6-40dB)
		2.2 (6-80dB)	2.2 (6-80dB)	2.2 (6-80dB)	2.2 (6-80dB)	4.4 (6-60dB)
Ultimate attenuation (dB)	>45	>100	>100	>100	>90	>90

Table 5.11: KVG 9MHz crystal filters for SSB, AM, FM and CW bandwidths

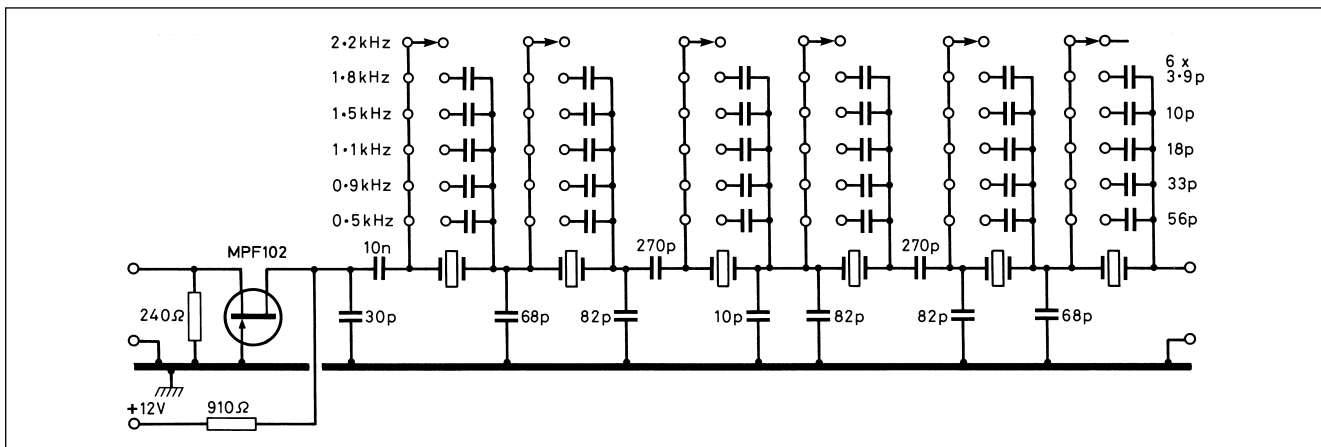

Fig 5.67: Y27YO described this six-section 4.433MHz ladder filter with switch-selectable bandwidth in *Funkamateur 1/85*. The FET buffer is included to present a stable, non-reactive load to the preceding diode mixer and the proper source impedance to the filter. While it uses inexpensive components, including PAL TV colour-burst crystals, careful shielding between sections is required and construction and test demand skill and proper instrumentation

Ladder crystal filters using inexpensive consumer (3.58MHz telephone and 3.579, 4.433 or 8.867MHz TV colour-burst) crystals have been successfully made by many amateurs. A word of warning: these crystals were made for parallel-resonant oscillator service; their parallel-resonant frequencies with a given load capacitance, typically 20pF, were within 50ppm or so when new. Their series-resonant frequencies, unimportant for their original purpose but paramount for filter application, can differ by much more. It therefore is very useful to have many more crystals than needed so that a matched set can be selected.

To design a filter properly around available crystals one must know their characteristics. They can be measured with the test circuit of Fig 5.66, where the three positions of S1 yield three equations for the three unknowns L_s , C_s and C_p . R_s can be measured after establishing series-resonance with S1 in position 3 by substituting non-inductive resistors for the crystal without touching the frequency or output level of the signal generator. A resistor which gives the same reading on the output meter as the crystal is equal to R_s . Note that the signal generator must be capable of setting and holding a frequency within 10Hz or so. All relevant information and PC programs to simplify the calculations are given in [23].

If a sweep generator and 'scope are used to adjust or verify a completed filter, the sweep speed must be kept very low: several seconds per sweep. Traditionally this has been done by using 'scopes with long-persistence CRTs. Sampling 'scopes, of course, can take the place of long-persistence screens.

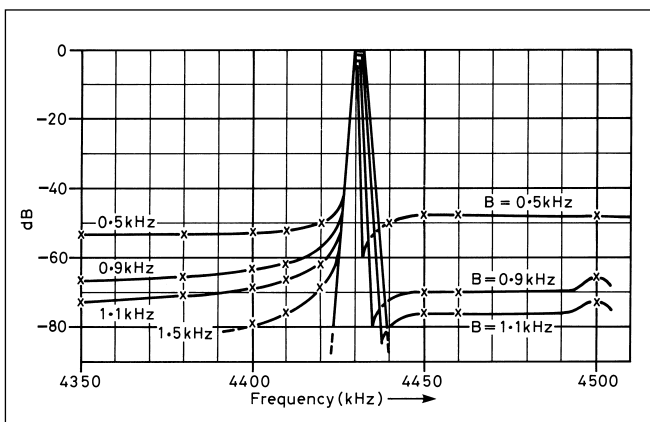

Fig 5.68: Response curves of the the Y27YO filter

The home-made filter of Fig 5.67, described by Y27YO, uses six 4.433MHz PAL colour TV crystals [24]. The filter bandwidth can be changed by switching different load capacitors across each crystal. See Fig 5.68. Note that at the narrower bandwidths the ultimate attenuation is reduced because of the greater load capacitors shunting each crystal. Each crystal with its load capacitors and switch wafer should be in a separate shielding compartment.

The input impedance of any crystal filter just above and below its pass-band is far from constant or non-reactive; therefore it is unsuitable as a termination for a preceding diode-ring mixer,

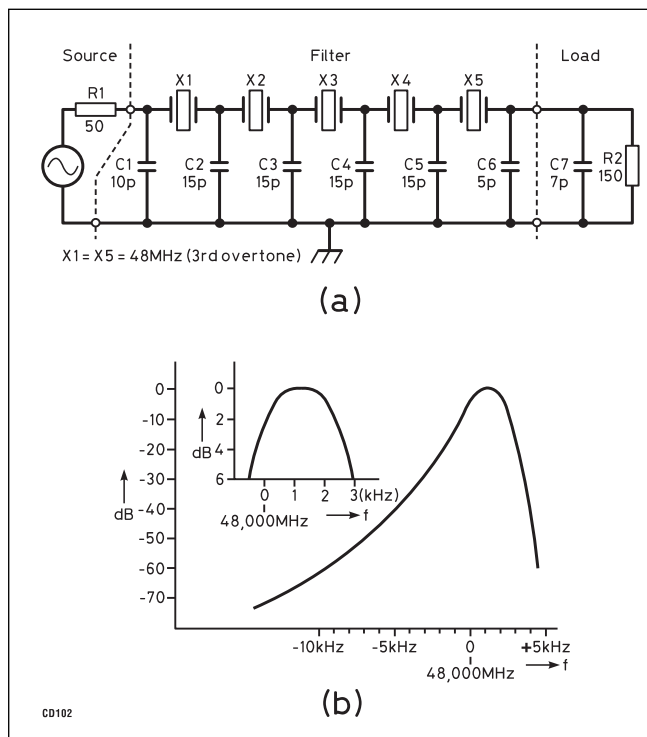

Fig 5.69: Overtone crystals, always marked with their series-resonant frequency, are used in this 48MHz ladder filter. This design by J Wieberdink from the Dutch magazine *Radio Bulletin 10/83* makes a good roofing filter for an HF SSB/CW receiver, but its top is too narrow to pass AM or NBFM and its shallow skirt slope on the low side requires that it be backed up by another filter at a second or third IF

Centre frequency (f_0)	48.0012MHz
3dB bandwidth	2.6kHz
6dB bandwidth	3kHz
40dB bandwidth	9kHz
60dB bandwidth	15.1kHz
Spurious responses	< 70dB
Pass-band ripple	<0.2dB
Insertion loss	2.1dB

Table 5.12: Performance of the 48MHz crystal filter

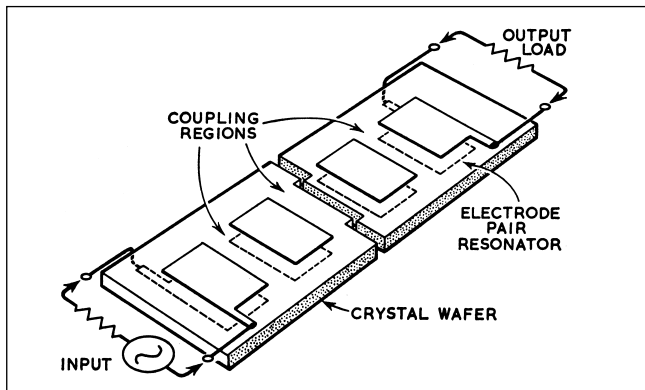

Fig 5.70: A monolithic crystal band-pass filter consists of several resonators, ie pairs of electrodes, on a single quartz plate. The coupling between the resonators is essentially mechanical through the quartz. Monolithic filters are mounted in three or four-pin hermetically sealed crystal holders. At HF, they are less expensive though less effective than the best discrete-component crystal filters, but they do make excellent VHF roofing filters

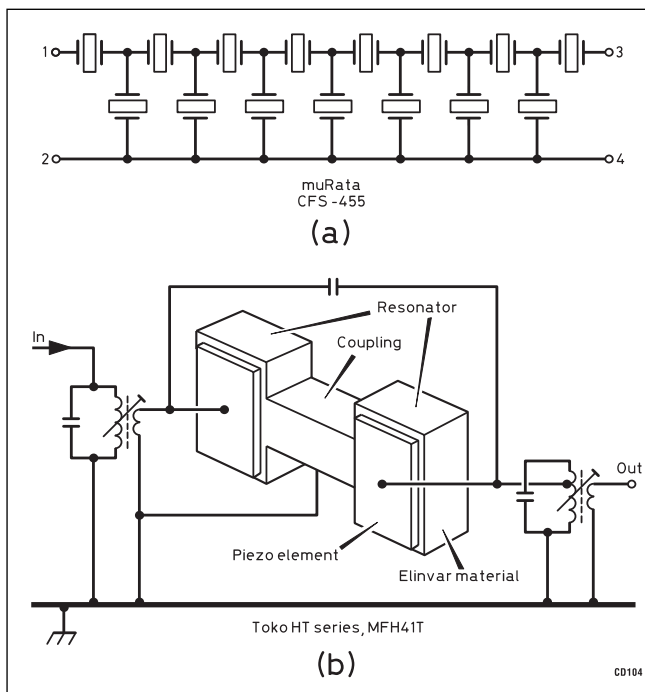

Fig 5.71: Ceramic band-pass filters are made in several configurations resembling those of crystal filters. While cheaper than the latter, they require more sections for a given filter performance, hence have greater insertion loss. Centre-frequency tolerances are 0.5% typical. Shown here are a ladder filter (a) and a monolithic filter (b)

which must have a fixed purely resistive load to achieve the desired rejection of unwanted mixing products. The inclusion in the Y27Y0 filter of a common-gate FET buffer solves this problem.

Virtually all available crystals above about 24MHz are overtone crystals, which means that they have been processed to have high Q at the third or fifth mechanical harmonic of their fundamental frequency. Such crystals can be used in filters. The marking on overtone crystals is their series resonant frequency, which is the one that is important in filters.

48MHz is a common microprocessor clock frequency and third-overtone crystals for it are widely available and relatively inexpensive. 48MHz also is a suitable first IF for dual- or triple-conversion HF receivers, which then require a roofing filter at that frequency. PAOSE reported on the 48MHz SSB filter design shown in Fig 5.69. Prototype data are shown in Table 5.12 - these were measured with a 50Ω source and 150Ω//7pF as shown in Fig 5.61.

Adequate shielding of the whole filter and between its sections is essential at this high frequency.

Monolithic crystal filters

Several pairs of electrodes can be plated onto a single quartz blank as in Fig 5.70. This results in a multi-section filter with the coupling between elements being mechanical through the quartz. Monolithic crystal filters in the 10-100MHz range are used as IF filters where the pass-band must be relatively wide, ie in AM and FM receivers and as roofing filters in multimode receivers.

Ceramic filters

Synthetic (ceramic) piezo-electric resonators are being made into band-pass filters in the range of 400kHz to 10.7MHz. Monolithic, ladder and half-lattice crystal filters all have their ceramic equivalents. Cheaper, ceramic resonators have lower Q than quartz crystals and their resonant frequencies have a wider tolerance and are more temperature dependent. While ceramic band-pass filters with good shape factors are made for bandwidths commensurate with AM, FM and SSB, they require more sections to achieve them, hence their insertion loss is greater. Care must be taken that BFOs used with them have sufficient frequency adjustment range to accommodate the centre frequency tolerance of a ceramic filter, eg $455 \pm 2\text{kHz}$ at 25 °C. Input and output matching transformers are included in some ceramic filter modules. Fig 5.71 shows a Murata ladder filter and a Toko monolithic filter.

Active filters

When designing LC audio filters, it is soon discovered that the inductors of values one would wish to use are bulkier, more expensive and of lower Q than the capacitors. Moreover, this lower Q requires the use of more sections, hence more insertion loss and even greater bulk and cost. One way out is the active filter, a technique using an amplifier to activate resistors and capacitors in a circuit which emulates an LC filter. Such amplifiers can be either single transistors or IC operational amplifiers, both being inexpensive, small, miserly with their DC supply, and capable of turning insertion loss into gain. Most active audio filters in amateur applications use two, three or four two-pole sections, each section having an insertion voltage gain between one and two. Filter component (R and C) accuracies of better than 5% are generally adequate, polystyrene capacitors being preferred. The advantage of op-amps over single transistors is that the parameters of the former do not appear in the transfer (ie output vs input) function of the filter, thereby simplifying the calculations.

Note that most IC op-amps are designed to have a frequency response down to DC. To allow both positive and negative outputs, they require both positive and negative supply voltages. In AC-only applications, however, this can be circumvented. In a single 13.8V

DC supply situation, one way is to bridge two series-connected 6.8kΩ 1W resistors across that supply, each bypassed with a 100μF/16V electrolytic capacitor; this will create a three-rail supply for the op-amps with 'common' at +6.9V, permitting an output swing up to about 8V p-p. The input and output of the filter must be blocked for DC by capacitors.

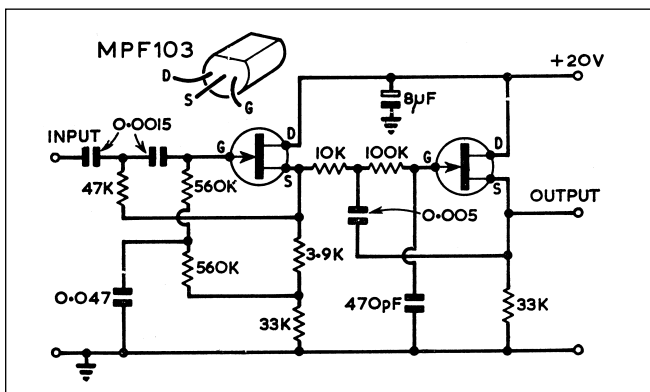

Fig 5.72: The ZL2APC active band-pass audio filter using FETs and a single DC supply

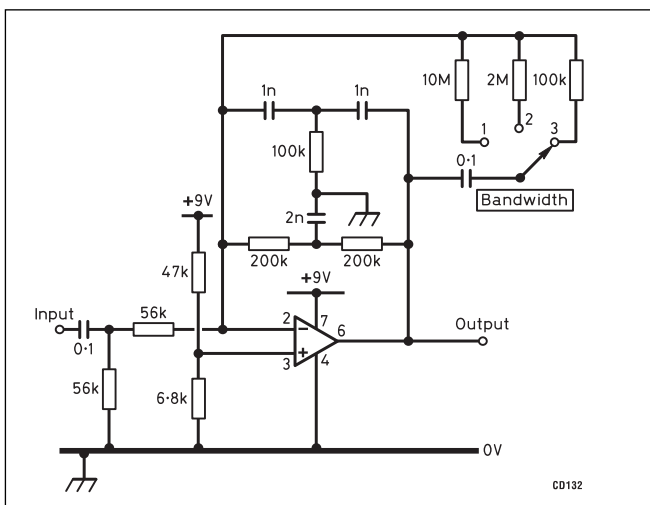

Fig 5.73: G3SZW put an 800Hz twin-T filter in the feedback loop of an op-amp to obtain a peak filter, then widened the response to usable proportions with switch-selectable resistors: to 60 and 180Hz (positions 1 and 2) for CW or 300-3500Hz (position 3) for voice. This filter does not require dual DC supplies

A complete active filter calculation guide is beyond the scope of this book but some common techniques are presented in the General Data chapter. Here, however, follow several applications, one with single transistors and others using op-amps.

A discrete-component active filter, which passes speech but rejects the bass and treble frequencies which do not contribute to intelligibility, is shown in Fig 5.72. This filter, designed by ZL2APC, might be used to provide selectivity for phone reception with a direct-conversion receiver (though it must be pointed out that active filters do not have sufficient dynamic range to do justice to those very best DC receivers, which can detect microvolt signals in the presence of tens of millivolts of QRM on frequencies which the audio filter is required to reject).

A twin-T filter used in the feedback loop of an op-amp is shown in Fig 5.73. A twin-T filter basically is a notch filter which rejects one single frequency and passes all others. With the R and C values shown, that frequency is about 800Hz. Used in the feedback loop of an op-amp, as in this design by G3SZW, the assembly becomes a peak filter which passes only that one frequency, too sharp even for CW. G3SZW broadened the response by shunting switch-selectable resistors across the twin-T; to 60Hz with 10MΩ, 180Hz with 2MΩ, and from 300Hz to 3500Hz, for phone, with 100kΩ.

Twin-T filters require close matching of resistors and capacitors. That would, in this example, be best accomplished by using four identical 1nF capacitors and four identical 200kΩ resistors, using two of each in parallel to make the 2nF capacitors and 200k resistors.

This circuit also demonstrates another technique for the use of op-amps on a single supply, here 9V. The DC level of both inputs is set by the voltage divider to which the (+) input is connected:

$$[6.8 / (6.8 + 47)] \times 9 = 1.14V$$

The op-amp's DC output level is set by its DC input voltage and inverting gain:

$$1.14 + [(200 + 200) / (56 + 56)] \times 1.14 = 5.2V$$

roughly half-way between +9V and earth. The capacitor in series with the bandwidth switch is to prevent the lowest bandwidth resistor from upsetting the DC levels. The input and output blocking capacitors have the same purpose with respect to any DC paths through the signal source or load.

A CW filter with two 741 or 301A op-amps in a multiple-feedback, band-pass configuration was described by LA2IJ and LA4HK [25], and is shown in Fig 5.74. It would be a worthwhile accessory with a modern transceiver lacking a narrow crystal filter.

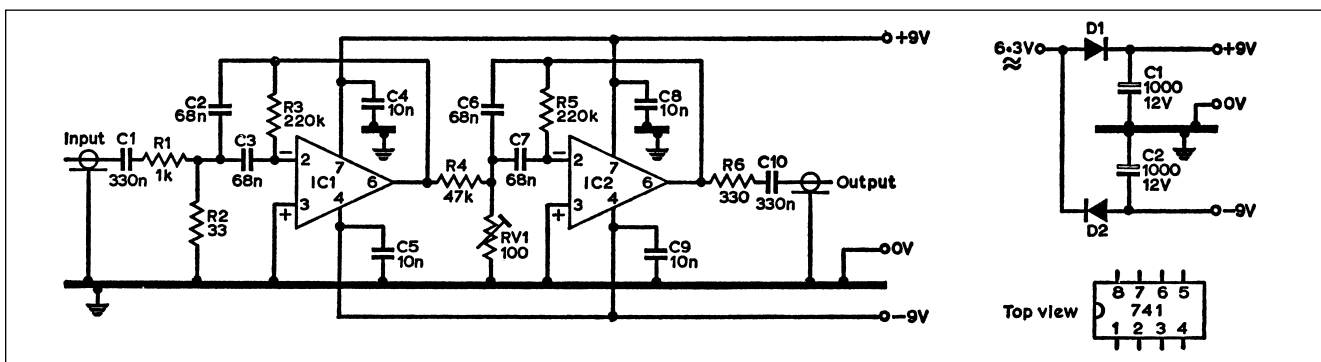

Fig 5.74: This CW band-pass filter using two multiple-feedback stages comes from LA2IJ and LA4HK. The centre frequency of the second stage can be equal to or offset from the first. If the two frequencies coincide, the overall bandwidth is 50Hz at 6dB (640Hz at 50dB), if staggered 200Hz (1550Hz). The dual power supply is derived from 6.3VAC, available in most valved receivers or transmitters

The first stage is fixed-tuned to about 880Hz, depending partly on the value of R2. The corresponding resistor in the second stage is variable and with it the resonant frequency can be adjusted to match that of the first stage, or to a slight offset for a double-humped band-pass characteristic. In the first state the filter has a pass-band width of only 50Hz at -6dB (about 640Hz at -50dB). When off-tuned the effective pass-band can be widened to about 200Hz (1550Hz).

Note that a bandwidth as narrow as 50 Hertz is of value only if the frequency stability of both the transmitter and receiver is such that the beat note does not drift out of the pass-band during a transmission, a stability seldom achieved with free-running home-built VFOs. Few analogue filters can compete with the ears of a skilled operator when it comes to digging out a weak wanted signal from among much stronger QRM.

A scheme to provide second-order CW band-pass filtering or a tuneable notch for voice reception was described by DJ6HP [26]. It is shown in Fig 5.75, and is based on the three-op-amp so-called state variable or universal active filter. The addition of a fourth op-amp, connected as a summing amplifier, provides a notch facility.

The resonant Q can be set between 1 and 5 with a single variable resistor and the centre frequency can be tuned between 450 and 2700Hz using two ganged variable resistors.

Switched-capacitor filters

The switched-capacitor filter is based on the digital processing of analogue signals, ie a hybrid between analogue and digital signal processing. It depends heavily on integrated circuits for its implementation. It pays to study the manufacturers' data sheets of devices under consideration before making a choice.

WB4TLM/KB4KVE describe the operation of switched-capacitor filters as follows: "The SCF works by storing discrete samples of an analogue signal as a charge on a capacitor. This charge is transferred from one capacitor to another down a chain of capacitors forming the filter. The sampling and transfer operations take place at regular intervals under control of a precise frequency source or clock. Filtering is achieved by combining the charges on the different capacitors in specific ratios and by feeding charges back to the prior stages in the capacitor chain. In this way, filters of much higher performance and complexity may be synthesised than is practical with analogue filters".

Fig 5.76 shows the circuit of an active low-pass filter which has a Butterworth (maximally flat) type of response and is a fourth-order design. Outside the passband, the attenuation of a fourth-order filter increases at 24dB/octave. The filter was designed using an active filter design reference book [27].

The values of R and C were set to R = 10k Ω and C = 5n6. This gives a cut-off frequency (where the amplitude vs frequency response curve is 3dB down) of 2.8kHz. The 5n6 capacitors should be polystyrene types because this gives the best audio quality. The filter was designed to improve the overall selectivity of a receiver which has poor IF selectivity, but could also be used in a transmitter to limit the bandwidth of the radiated signal. The op-amps were contained within a NE5532 type dual op-amp package, and pin numbers are given for this device. The resistor

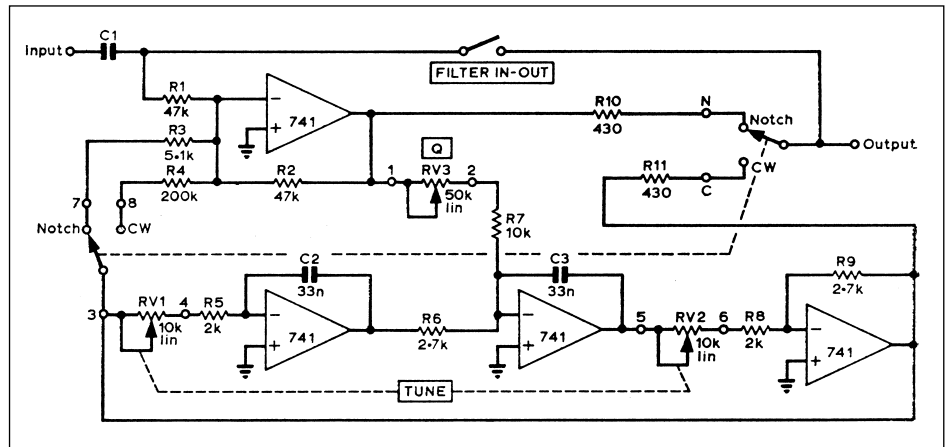

Fig 5.75: A universal filter scheme described by DJ6HP provides variable-Q band-pass filtering for CW or a tunable notch for 'phone. Dual DC supplies between $\pm 9V$ and $\pm 15V$ are required

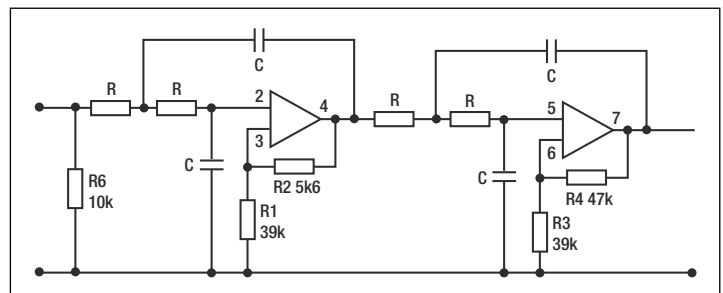

Fig 5.76: Audio low-pass filter, fourth-order Butterworth design

R6 is a bias resistor, and is required only if the source does not have a DC path to supply bias current for input pin 2 of the NE5532. The power supply used was $\pm 12V$.

VOLTAGE REGULATORS

The voltage regulator is an important building block. Ideally, it provides a constant output DC voltage, which is independent of the input voltage, load current and temperature. If the voltage regulator is used to regulate the supply to a VFO (for example) then it will not be affected by variations in supply voltage. For sensitive circuits like the VFO, this is a significant benefit. This allows circuits to be designed to operate at one voltage, which eases the design. As well as the DC parameters of regulators, most circuits also provide a significant isolation of high frequencies. This isolation is provided partly by the decoupling capacitors which accompany the regulator, and partly by the electronic isolation of the regulator itself. IC type regulators are now so cheap (typically 50p for an LM317) that it is economical to use one for each stage of a complex circuit. For example, in a frequency synthesiser separate regulators could be used for:

- The VCO
- The VCO buffer/amplifier stage
- The reference oscillator
- The digital divider circuits

More on regulators can be found in the power supplies chapter.

ATTENUATORS

Attenuators are resistor networks which reduce the signal level in a line while maintaining its characteristic impedance. Table 5.13 gives the resistance values to make up 75 Ω and 50 Ω unbalanced RF T- and pi-attenuators; the choice between the T- and pi- configurations comes down to the availability of resistors

Attenuation (dB)	50Ω T-pad		75Ω T-pad		Attenuation (dB)	50Ω π-pad		75Ω π-pad	
	R1	R2	R1	R2		R3	R4	R3	R4
1	2.9	433	4.3	647	1	5.8	870	8.6	1305
2	5.7	215	8.6	323	2	11.6	436	17.4	654
3	8.5	142	12.8	213	3	17.6	292	26.4	439
4	11.3	105	17.0	157	4	23.8	221	35.8	331
5	14.0	82	21.0	123.4	5	30.4	179	45.6	268
6	16.6	67	25.0	100	6	37.3	151	56.0	226
7	19.0	56	28.7	83.8	7	44.8	131	67.2	196
8	21.5	47	32.3	71	8	52.3	116	79.3	174
9	23.8	41	35.7	61	9	61.6	105	92.4	158
10	26.0	35	39.0	52.7	10	70.7	96	107	144
11	28.0	30.6	42.0	45.9	11	81.6	89	123	134
12	30.0	26.8	45.0	40.2	12	93.2	84	140	125
13	31.7	23.5	47.6	35.3	13	106	78.3	159	118
14	33.3	20.8	50.0	31.2	14	120	74.9	181	112
15	35.0	18.4	52.4	25.0	15	136	71.6	204	107
20	41.0	10.0	61.4	15.2	20	248	61	371	91.5
25	44.7	5.6	67.0	8.5	25	443	56	666	83.9
30	47.0	3.2	70.4	4.8	30	790	53.2	1186	79.7
35	48.2	1.8	72.4	2.7	35	1406	51.8	2108	77.7
40	49.0	1.0	73.6	1.5	40	2500	51	3750	76.5

Table from *Datacom*.

Table 5.13. Resistor values for 50-ohm and 75-ohm T- and pi-attenuators

close to the intended values, which can also be made up of two or more higher values in parallel; the end result is the same. Attenuators are also discussed in the chapter on test equipment. Here are some of the applications:

Receiver Overload

Sensitive receivers often suffer overload (blocking, cross-modulation) from strong out-of-band unwanted signals which are too close to the wanted signal to be adequately rejected by preselector filters. This condition can often be relieved by an attenuator in the antenna input. In modern receivers, one reduction of sensitivity is usually provided for by a switch which removes the RF amplifier stage from the circuit; and another reduction by switching in an attenuator, usually 20dB.

There is an additional advantage of an attenuator. However carefully an antenna may be matched to a receiver at the wanted frequency, it is likely to be grossly mismatched at the interfering

frequency, leaving the receiver's preselector filter poorly terminated and less able to do its job. A 10dB attenuator keeps the nominally 50Ω termination of the preselector filter between 41 and 61Ω under all conditions of antenna mismatch.

An S-meter as a Field Strength Meter

When plotting antenna patterns, the station receiver is often used as a field strength indicator. As the calibration of S-meters is notoriously inconsistent, it is better to always use the same S-meter reading, say S9, and to adjust the signal source or the receiver sensitivity to get that reading at a pattern null. All higher field strengths are then reduced to S9 by means of a calibrated switchable attenuator.

A suitable attenuator, with a range of 0 - 41dB in 1dB steps, is shown in Fig 5.77. Such an attenuator bank can be constructed from 5% carbon composition or film resistors of standard values and DPDT slide switches, eg RS 337-986. The unit is assembled

Fig 5.77: 50Ω attenuator with a 0-41dB range in 1dB steps. At RF, it is unwise to try to get more than 20dB per step because of stray capacitances. (ARRL Handbook)

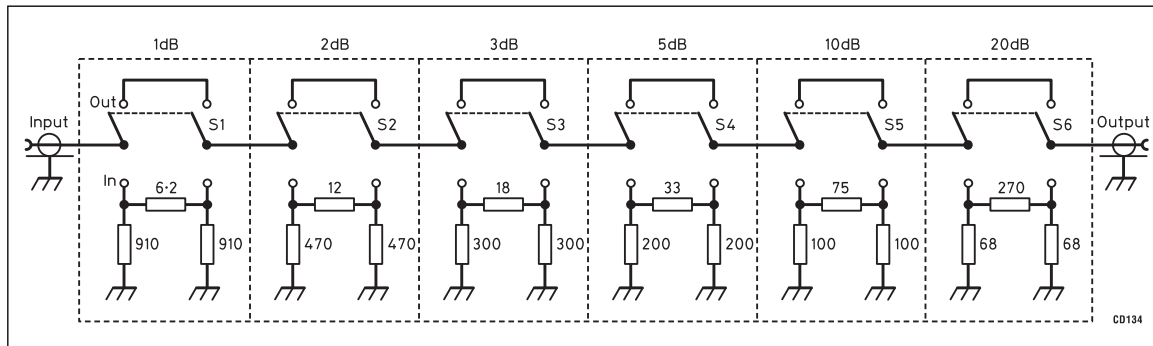

in a tin-plate box; shields between individual attenuators reduce capacitive coupling and can be made of any material that is easy to cut, shape and solder, ie tin plate, PCB material or copper gauze. At VHF, the unit is still useful but stray capacitances and the self-inductance of resistors are bound to reduce accuracy. Verification of the accuracy of each of the six sections can be done at DC, using a volt or two from a battery or PSU and a DVM; do not forget to terminate the output with a 50Ω resistor.

Driving VHF Transverters

RF attenuators may sometimes be used at higher powers, eg where an HF transmitter without a low-level RF output is to drive, but not to overdrive, a VHF transverter. Care must be taken to ensure that the resistors can handle the power applied to them.

STONE SIGNALLING: CTCSS

If an FM receiver requires, for its squelch to open and remain open, not only a carrier of sufficient strength but also a tone of a specific frequency, much co-channel interference can be avoided. If a repeater transmits such a tone with its voice transmissions but not with its identification, a continuous-tone coded squelch system (CTCSS) equipped receiver set for the same tone would hear all that repeater's voice transmissions but not its idents. Its squelch would not be opened either, eg during lift conditions, by a repeater on the same channel but located in another service area and sending another CTCSS tone. Conversely, a mobile, positioned in an overlap area between two repeaters on the same channel but which have their receivers set for different CTCSS tones, could use one repeater without opening the other by sending the appropriate tone.

Similar advantages can be had where several groups of stations, each with a different CTCSS tone, share a common frequency. With all transceivers within one group set for that group's tone, conversations within the group would not open the squelch of stations of other groups monitoring the same frequency.

The Electronic Industries Association (EIA) has defined 38 CTCSS standard sub-audible tone frequencies. They are all between 67 and 250.3Hz, ie within the range of human hearing but outside the 300-3000Hz audio pass-band of most communications equipment and their level is set at only 10% of maximum deviation for that channel; hence sub-audible.

The left column of **Table 5.14** gives the frequency list. CTCSS encoders (tone generators) and also decoders (tone detectors) are offered as options for many earlier mobile and hand-held VHF and UHF FM transceivers. Most current transceivers have CTCSS encode built-in as standard.

Commercial standards require encoder frequencies to be within 0.1% of the nominal tone frequency under all operating conditions, attainable only with crystal control; most amateur repeaters are more tolerant, however, and RC-oscillators have

Nominal frequency (Hz)	FX365 frequency (Hz)	Δfo (%)	D0	D1	D2	D3	D4	D5
67.0	A 67.05	+0.07	1	1	1	1	1	1
71.9	B 71.90	0.0	1	1	1	1	1	0
74.4	74.35	0.07	0	1	1	1	1	1
77.0	C 76.96	0.05	1	1	1	1	0	0
79.7	79.77	+0.09	1	0	1	1	1	1
82.5	D 82.59	+0.10	0	1	1	1	1	0
85.4	85.38	0.02	0	0	1	1	1	1
88.5	E 88.61	+0.13	0	1	1	1	0	0
91.5	91.58	+0.09	1	1	0	1	1	1
94.8	F 94.76	0.04	1	0	1	1	1	0
97.4	97.29	0.11	0	1	0	1	1	1
100.0	99.96	0.04	1	0	1	1	0	0
103.5	G 103.43	0.07	0	0	1	1	1	0
107.2	107.15	0.05	0	0	1	1	0	0
110.9	H 110.77	0.12	1	1	0	1	1	0
114.8	114.64	0.14	1	1	0	1	0	0
118.8	J 118.80	0.0	0	1	0	1	1	0
123.0	122.80	0.17	0	1	0	1	0	0
127.3	127.08	0.17	1	0	0	1	1	0
131.8	131.67	0.10	1	0	0	1	0	0
136.5	136.61	+0.08	0	0	0	1	1	0
141.3	141.32	+0.02	0	0	0	1	0	0
146.2	146.37	+0.12	1	1	1	0	1	0
151.4	151.09	0.20	1	1	1	0	0	0
156.7	156.88	+0.11	0	1	1	0	1	0
162.2	162.31	+0.07	0	1	1	0	0	0
167.9	168.14	+0.14	1	0	1	0	1	0
173.9	173.48	0.19	1	0	1	0	0	0
179.9	180.15	+0.14	0	0	1	0	1	0
186.2	186.29	+0.05	0	0	1	0	0	0
192.8	192.86	+0.03	1	1	0	0	1	0
203.5	203.65	+0.07	1	1	0	0	0	0
210.7	210.17	0.25	0	1	0	0	1	0
218.1	218.58	+0.22	0	1	0	0	0	0
225.7	226.12	+0.18	1	0	0	0	1	0
233.6	234.19	+0.25	1	0	0	0	0	0
241.8	241.08	0.30	0	0	0	0	1	0
250.3	250.28	0.01	0	0	0	0	0	0
No tone	No tone	-	0	0	0	0	1	1

From Consumer Microelectronics Ltd IC Data Book, 1st edn

Table 5.14: CTCSS (continuous tone coded squelch system) EIA-standard frequencies. The letters behind some frequencies refer to the tones used by UK voice repeaters. The eight right-hand columns refer to the FX365 LSI chip (see text)

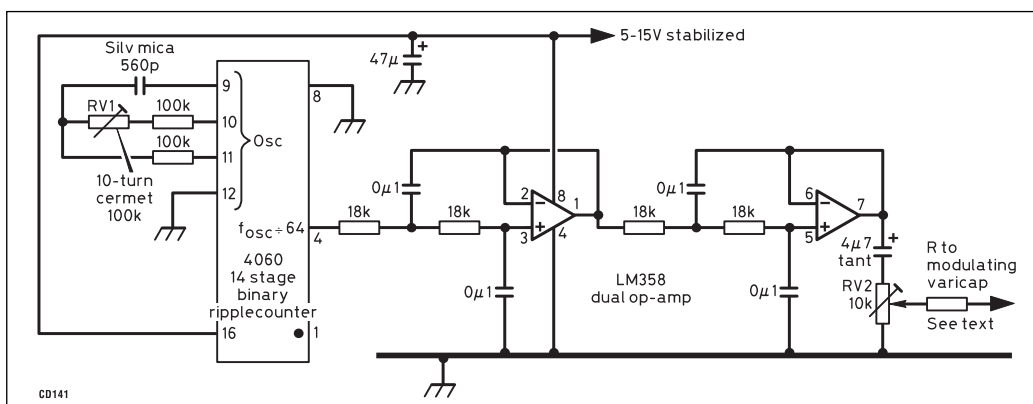

Fig 5.78: The Tuppenny simple CTCSS encoder (G0CBM) consists of an RC oscillator and +64 divider in one CMOS IC, together with a two-stage active LP filter built around a dual op-amp (G8HLE) (Kent Repeater Newsletter)

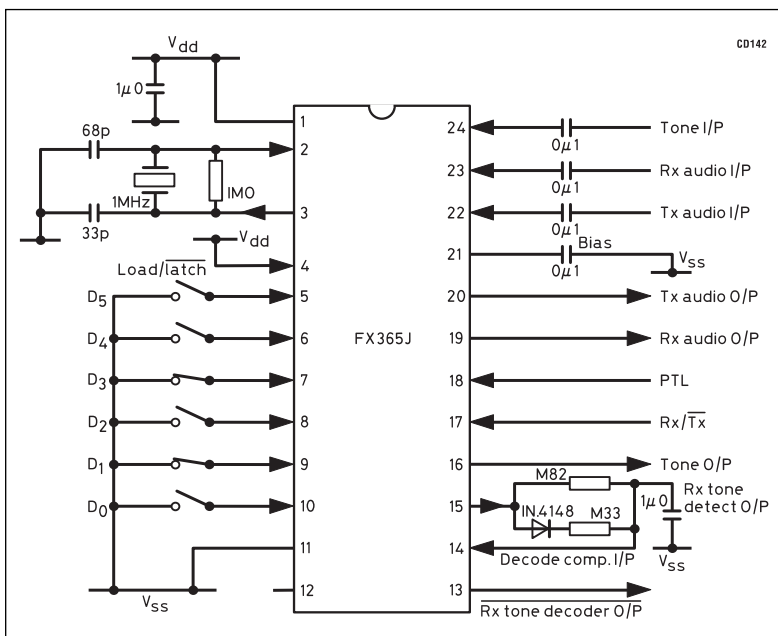

Fig 5.79: CTCSS encoder/decoder using a CML CMOS LSI device. The chip also contains 300Hz-cut-off HP and LP filters to separate tones and speech and a crystal reference oscillator. Tone selection can be by microprocessor or hard-wired switches (Consumer Microcircuits IC Data Book)

been used successfully. The encoder tone output must be a clean sine wave lest its harmonic content above 300Hz becomes audible; this requires good filtering.

GOCBM's very simple Tuppenny CTCSS tone generator was designed for retrofitting in a surplus PMR transmitter to access local repeaters: **Fig 5.78** [28]. It is built around the inexpensive CMOS oscillator-frequency divider IC 4060. The parts connected to pins 9, 10 and 11 are the frequency-determining components of the RC oscillator; they have a tolerance of 5% but parts with the lowest possible temperature coefficient should be chosen to obtain adequate frequency stability, especially under mobile operation. RV1 allows frequency adjustment over the range 4288-7603Hz, which, after dividing by 64, yields at pin 4 any CTCSS frequency between 67 and 119Hz; this includes tones A-J assigned to UK repeaters.

A two-stage active low-pass filter was designed by G8HLE to get sufficient suppression of any harmonics above 300Hz of all tones. The LM358 dual op-amp was chosen because it is small, cheap and works on a low, single supply voltage. The -6dB frequency was chosen at 88Hz, ie the higher tones to be passed fall outside the pass-band.

As the tone amplitude is far greater than required, this attenuation is no disadvantage, but each tone tuned in with RV1 requires a different setting of RV2 to get the same deviation. The output resistor R depends on the modulator circuitry in the transmitter. It should be dimensioned to get the proper CTCSS deviation at the highest tone frequency to be used with RV2 set near maximum.

Encoders/decoders are more complicated and the LSI CMOS device used, eg CML FX365, is expensive: **Fig 5.79** [29]. It contains not only the encoder and decoder proper, but also a high-pass filter which prevents any received CTCSS tone becoming audible, a low-pass filter to suppress harmonics of CTCSS tones and a crystal-controlled reference oscillator from which the tones are derived; see columns 2 and 3 of Table 5.16. Tone selection is according to the six right-hand columns of that table, either by microprocessor or by hard-wired switches. Another feature is transmit phase reversal on release of the PTT switch; this shortens the squelch tail at the receiver.

ANALOGUE-DIGITAL INTERFACES

Most real-world phenomena are analogue in nature, meaning they are continuously variable rather than only in discrete steps; examples are a person's height above ground going up a smooth wheel-chair ramp, the shaft angle of a tuning capacitor, the temperature of a heatsink and the wave shape of someone's voice. However, some are digital in nature, meaning that they come in whole multiples of a smallest quantity called least-significant bit (LSB); examples are a person's height going up a staircase (LSB is one step), telephone numbers (one cannot dial in between two numbers) and money (LSB is the penny/cent and any sum is a whole multiple thereof).

Frequently, it is useful to convert from analogue to digital and vice versa in an analogue-to-digital converter (ADC) or a digital-to-analogue converter (DAC). If anti-slip grooves with a pitch of, say, 1cm are cut across the wheelchair ramp, it has, in fact, become a staircase with minuscule steps (LSBs) which one can count to determine how far up one is, with any position between two successive steps being considered trivial. Without going into details of design, a number of conversions commonly employed in amateur radio equipment will now be explained.

Shaft Encoders & Stepper Motors

Amateurs expect to twist a knob, an analogue motion, when they want to change frequency. Traditionally, that motion turned the shaft of a variable capacitor or screwed a core into or out of a coil.

Now that frequencies in many radios are generated by direct digital synthesis, a process more compatible with keyboard entry and up/down switches, amateurs not only still like to twist knobs, they also like them to feel like the variable capacitors of yesteryear; equipment manufacturers comply but what the knob actually does drive is an optical device called an incremental shaft encoder: **Fig 5.80** [30].

The encoder is often a disc divided into sectors which are alternately transparent and opaque. A light source is positioned at one side of the disc and a light detector at the other. As the tuning knob is spun and the disc rotates, the output from the detector goes on or off when a transparent or an opaque disc sector is in the light path. Thus, the spinning encoder produces a stream of pulses which, when counted, indicate the change of angular position of the shaft. A second light source and detector pair, at an angle to the main pair, indicates the direction of rotation. A third pair sometimes is used to sense the one-per-revolution marker seen at the right on the disc shown.

Available encoder resolutions (the number of opaque and transparent sectors per disc) range from 100 to 65,000. The SSB/CW tuning rate of one typical radio was found to be 2kHz per knob rotation in 10Hz steps; this means an encoder resolution of 200. The ear cannot detect a 10Hz change of pitch at 300Hz and above, so the tuning feels completely smooth, though its output is a digital signal in which each pulse is translated into a 10Hz frequency increment or decrement.

Stepper motors do the opposite of shaft encoders; they turn a shaft in response to digital pulses, a step at a time. Typical motors have steps of 7.5 or 1.8 degrees; these values can be halved by modifying the pulse sequence.

Pulses vary from 12V at 0.1A to 36V at 3.5A per phase (most motors have four phases) and are applied through driver ICs for small motors or driver boards with ICs plus power stages for big ones. The drivers are connected to a control board which in turn may be software-programmed by a computer, eg via an RS232

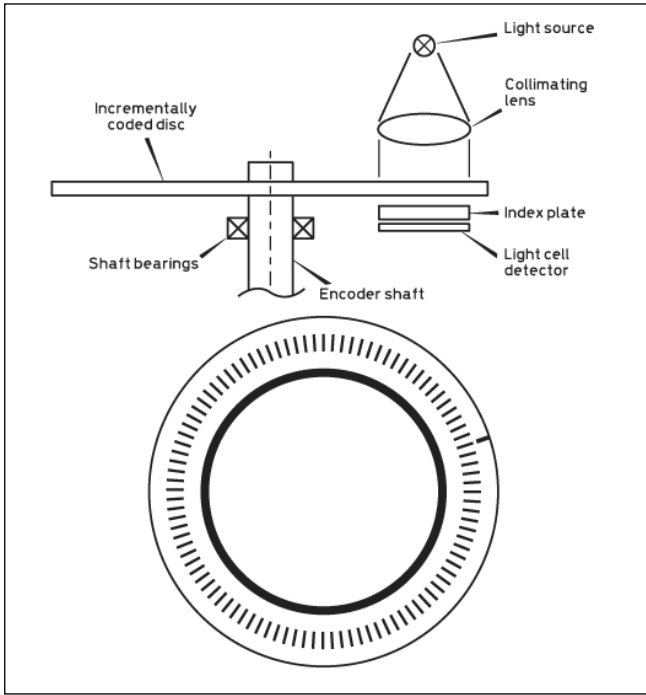

Fig 5.80: The incremental shaft encoder. In some radios with digital frequency synthesis, the tuning knob turns the shaft which turns the disc which alternately places transparent and opaque sectors in the light path; each pulse from the light detector increases or decreases the frequency by one step. (Taken from *Analog-Digital Conversion Handbook*, 3rd edn, Prentice-Hall, 1986, p444, by permission. Copyright Analog Devices Inc, Norwood, MA, USA)

link (a standard serial data link). In amateur radio they are used on variable capacitors and inductors in microprocessor-controlled automatic antenna tuning units and on satellite-tracking antenna azimuth and elevation rotators.

Digitising Speech

While speech can be stored on magnetic tape, and forwarded at speeds a few times faster than natural, each operation would add a bit of noise and distortion and devices with moving parts, ie tape handling mechanisms, are just not suitable for many environments. Digital speech has changed all that. Once digitised, speech can be stored, filtered, compressed and expanded by computer, and forwarded at the maximum speed of which the transmission medium is capable, all without distortion; it can then be returned to the analogue world where and when it is to be listened to.

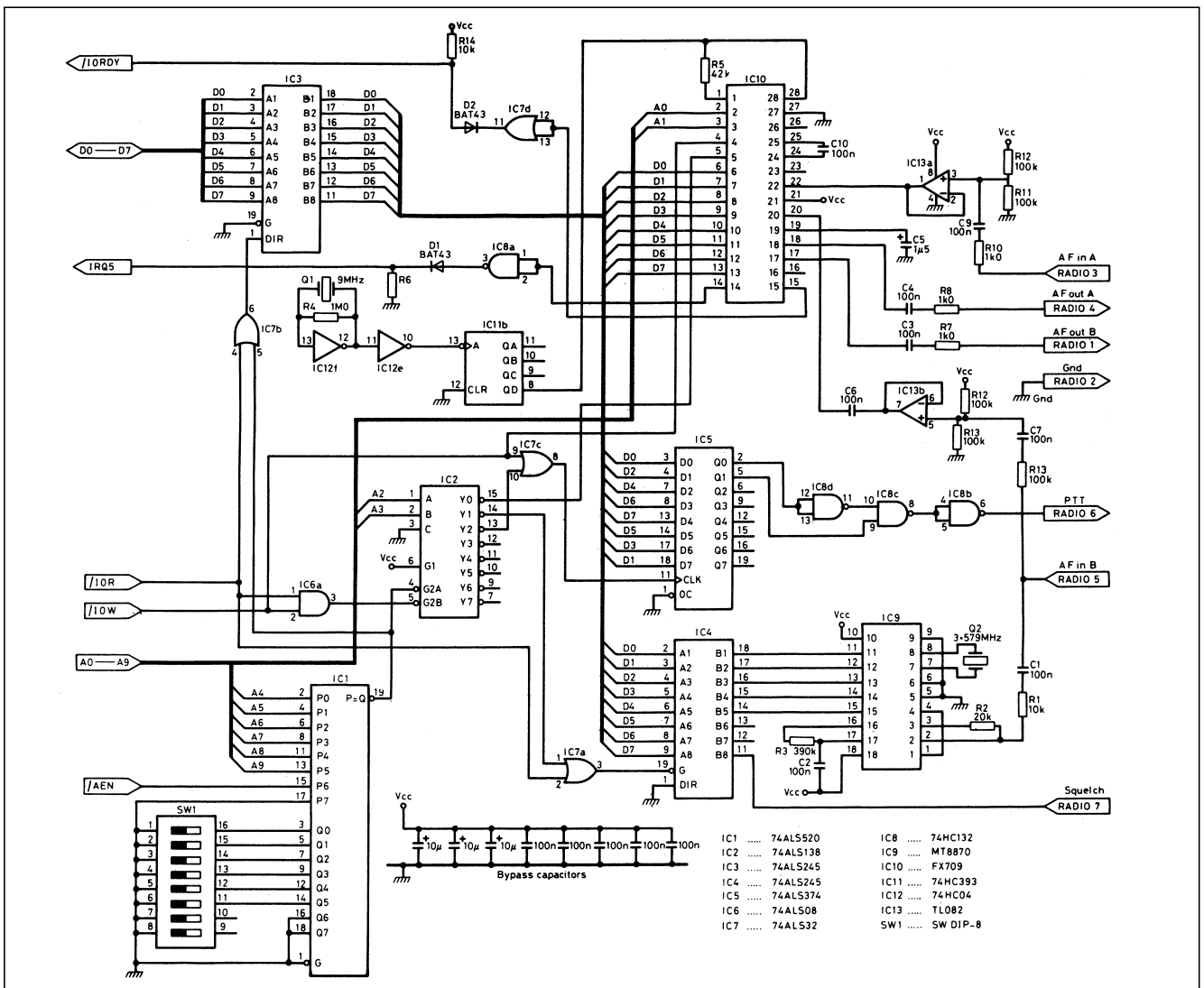

Fig 5.81: Speech encoder/decoder designed by DG3RBU and DL8MBT for voice mailboxes on UHF FM repeaters

If speech were to be digitised in the traditional way, ie sampled more than twice each cycle on the highest speech frequency, eg at 7kHz for speech up to 3kHz, and 10-bit resolution of the amplitude of each sample were required for reasonable fidelity, a bit rate of 70kbit/s would result, about 20 times the 3.5kHz bandwidth considered necessary for the SSB transmission of analogue speech. Also, almost a megabyte of memory would be required to store each minute of digitised speech. Differential and adaptive techniques are used to reduce these requirements.

DG3RBU and DL8MBT developed hardware and software for the digital storage and analogue retransmission of spoken messages on normal UHF FM voice repeaters and the digital forwarding of such messages between repeaters via the packet network. They described their differential analogue-digital conversion as follows.

"The conversion is by continuously variable slope decoding (CVSD), a form of delta modulation; in this process it is not the instantaneous value of an analogue voltage that is being sampled and digitised but its instantaneous slope at the moment of sampling. Binary '1' represents an increasing voltage, '0' a decreasing voltage.

"Encoding the slope of the increase or decrease depends on the prior sample. If both the prior and present samples are '1', a steeper slope is assumed than when a '1' follows a '0'. Decoding does the same in reverse. This system of conversion is particularly suitable for speech; even at a relatively modest data rate of 16kbit/s it yields good voice quality. An FX709 chip is used.

"The analogue-to-digital converter (ADC) for speech input and digital-to-analogue converter (DAC) for speech output are assembled on a specially designed plug-in board for an IBM PC computer, **Fig 5.81** [31]. It provides all the required functions, starting with the address coding for the PC (IC1 and 2). In the FX709 (IC10), the signal passes through a bandpass filter to the one-bit serial encoder; after conversion to an eight-bit parallel format the data pass to the PC bus via IC3; in the other direction, voice signals pass through a software-programmable audio filter; registers for pause and level recognition complete the module.

"The FX709 has a loopback mode which permits a received and encoded speech signal to be decoded and retransmitted, an easy way to check the fidelity of the loop consisting of the radio receiver-encoder-decoder-radio transmitter. The built-in quartz clock oscillator (IC12f) and divider (IC11) permit experiments with different externally programmable clock rates.

"The maximum length of a text depends on the data rate. We used 32kbit/s, at which speed it is hard to tell the difference between the sound on the input and an output which has gone through digitising, storage, and reconversion to analogue.

"The maximum file length is 150s. The reason for this time limit is that the FX709 has no internal buffer; this requires that the whole file must be read from RAM in real time, ie without interrupts for access to the hard disk."

Digital Panel (volt) Meters (DPMs)

Analogue methods for DC voltage measurements, say with a resolution of a millivolt on a 13.8V power supply, are possible but cumbersome. With a digital voltmeter they are simple and comparatively inexpensive. Digital panel meters are covered in the Test Equipment chapter.

SOFTWARE BUILDING BLOCKS

The PIC [32] is a microcontroller which is being used more and more in amateur radio projects (for instance the one shown in Fig 5.82).

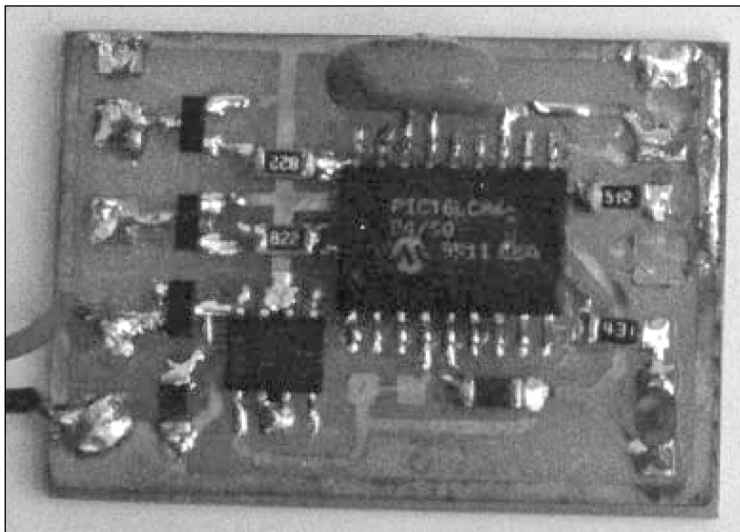

Fig 5.82: Postage stamp sized beacon keyer using a PIC chip

A PIC is an economical way of providing software control of functions in home-built amateur radio equipment. Examples of the use of PIC devices are:

- ATU control [33]
- DDS controller [34] (see also the oscillators chapter of this Handbook)
- Frequency-dependant switch [35]
- Bug key [36]
- Transceiver control [37]
- Keyer [38]
- Morse code speed calibrator [39]
- Morse code reader [40]

Note that the references above also have links to internet sites.

PIC Code

In some of the above projects, the PIC can be purchased ready programmed and this is an easy solution to reproduce a published design.

However, there are strong reasons for the constructor to write his or her own code:

- The constructor may wish to modify existing code to either modify an existing function or add extra requirements to an existing design.
- The constructor may wish to write all of the code from scratch.
- The existing design may be suitable, but further functions will be added in the future. For example, this may be caused by a change in amateur bands used, or a change of mode.

The ideal environment in which to develop PIC software is the MPLAB integrated package, which is available from the manufacturers of the PIC [32]. This runs on a PC, but the PC doesn't need to be sophisticated. An old, unused PC may be adequate.

For the purpose of developing software, it is recommended that PIC devices with on-board EEPROM are used. An example of a small PIC project is shown in **Fig 5.82**.

Further information on PIC programming can be found in the chapter on computers in the shack and from [41].

REFERENCES

- [1] W2CQH, QST, Jan 1974
- [2] Constant-R network. *RF Design Basics*, John Fielding, ZS5JF. RSGB, 2006
- [3] *Signetics RF Communications Handbook*
- [4] Ian Braithwaite, G4COL, *RadCom*, Jul 1997, pp38-39
- [5] <http://www.avagotech.com>
- [6] <http://www.mini-circuits.com>
- [7] Doug DeMaw, W1FB, QST, Apr 1989, pp30-33
- [8] Drew Diamond, VK3XU, *Amateur Radio*, 10/88
- [9] David Bowman, G0MRF, in *RadCom*, Feb 1993, pp28-30, and Mar 1993, pp28-29
- [10] Klaas Spaargaren, PA0KLS, in 'Eurotek', *RadCom*, Nov 1998 (corrections in *RadCom*, Jan 1999, p20)
- [11] http://www.frenning.dk/OZ1PIF_HOME/PAGE/50MHz_IRF510.htm
- [12] Zack Lau, KH6CP, QST, Oct 1987
- [13] PA0GMS in 'Eurotek', *RadCom*, Dec 1992, p49
- [14] E J Hatch, G3ISD, *RadCom*, May 1982 and Mar 1984
- [15] *VHF/UHF Manual*, ed G R Jessop, G6JP, 4th edn, RSGB, 1983
- [16] Mike Grierson, G3TSO, *Radio Communication*, Mar 1990, p35
- [17] *Radio Communication* August 1992, p39
- [18] 'Design a toroidal tank circuit for your vacuum tube amplifier', Robert E Bloom, W6YUY, *Ham Radio Magazine* (USA) Aug 1985
- [19] Analog Devices web site, <http://www.analog.com>
- [20] GW4NAH, *Radio Communication*, Jan 1989, p48
- [21] DF4ZS in 'Eurotek', *RadCom*, Oct 1998
- [22] ON5DI in 'Eurotek', *RadCom*, Dec 1998
- [23] 'Computer-aided ladder crystal filter design', J A Hardcastle, G3JIR, *Radio Communication*, May 1983
- [24] H R Langer, Y27Y0, *Funkamateur*, Jan 1985; *Radio Communication*, Jun 1985, p452
- [25] LA2IJ and LA4HK, *Amator Radio*, Nov 1974
- [26] DJ6HP, *cq-DL*, Feb 1974
- [27] *Active Filter Cookbook*, Don Lancaster. Howard W. Sams and Co. ISBN 0-672-21168-8
- [28] *Kent Repeater Newsletter*, Jan 1993
- [29] *IC Data Book*, 1st edition, Consumer Microcircuits Ltd, p2.40
- [30] *Analogue-Digital Conversion Handbook*, 3rd edition, Prentice-Hall, 1986, p215
- [31] *RadCom*, May 1992, p62
- [32] www.microchip.com
- [33] 'picATUe - the intelligent ATU', Peter Rhodes, G3XJP, *RadCom*, Sep 2000 to Jan 2001
- [34] 'Use of PICs in DDS Design' in 'Technical Topics' column, Pat Hawker G3VA. *RadCom*, Jan 2001
- [35] 'Pic-A-Switch A Frequency Dependent Switch', Peter Rhodes, G3XJP, *RadCom*, Sep - Dec 2001
- [36] 'Bugambic: Son of Superbug', Chas Fletcher, G3DXZ, *RadCom*, Apr 2002
- [37] 'CDG2000 HF Transceiver', Colin Horrabin, G3SBI, Dave Roberts, G3KBB, and George Fare, G3OGQ, *RadCom*, Jun 2002 to Dec 2002
- [38] 'The programmer and the keyer', Ed Chicken, G3BIK, *RadCom*, Nov 2004
- [39] 'A Morse Code Speed Calibrator'. Jonathan Gudgeon, G4MDU, *RadCom*, Aug 2004
- [40] 'A Talking Morse Code Reader', Jonathan Gudgeon, G4MDU, *RadCom*, Jun 2001
- [41] *Command*, Andy Talbot, G4JNT, RSGB, 2003

About the Author

Peter Goodson is qualified with a Hons Degree in Communication Engineering. He began his career working on the component-level design of HF (SSB) and VHF (FM) transceivers. He now works on the system level design of RF systems, which includes the issues of communications security, EMC, co-siting of radio equipment, RF hazard assessments and immunity to lightning strikes.

